



Subject: Global Infrastructure and Networks – GSS004 –Glass Fiber Reinforced Polyester Poles for Distribution Network

Application Areas
Perimeter: *Global*

Staff Function: -

Service Function: -

Business Line: *Infrastructure & Networks*
CONTENTS

| | | |
|----------|---|-----------|
| 1 | DOCUMENT AIMS AND APPLICATION AREA | 2 |
| 1.1 | <i>RELATED DOCUMENTS TO BE IMPLEMENTED AT COUNTRY LEVEL</i> | <i>2</i> |
| 2 | DOCUMENT VERSION MANAGEMENT | 3 |
| 3 | UNITS IN CHARGE OF THE DOCUMENT | 3 |
| 4 | REFERENCES | 3 |
| 5 | ORGANIZATIONAL PROCESS POSITION IN THE PROCESS TAXONOMY | 7 |
| 6 | DEFINITIONS AND ACRONYMS..... | 7 |
| 7 | DESCRIPTION | 8 |
| 7.1 | <i>LIST OF COMPONENTS.....</i> | <i>8</i> |
| 7.2 | <i>SERVICE CONDITIONS</i> | <i>11</i> |
| 7.3 | <i>TECHNICAL CHARACTERISTICS.....</i> | <i>11</i> |
| 7.4 | <i>CONSTRUCTION CHARACTERISTICS</i> | <i>14</i> |
| 7.5 | <i>DESIGNATION</i> | <i>23</i> |
| 7.6 | <i>MARKING.....</i> | <i>24</i> |
| 7.7 | <i>TESTING</i> | <i>28</i> |
| 7.8 | <i>TECHNICAL CONFORMITY ASSESSMENT.....</i> | <i>44</i> |
| 7.9 | <i>GUARANTEE.....</i> | <i>44</i> |
| 7.10 | <i>CONDITIONS OF SUPPLY.....</i> | <i>45</i> |
| 7.11 | <i>ANNEX A – COUNTRY CODE CONVERSION TO OLD SPECIFICATIONS</i> | <i>46</i> |
| 7.12 | <i>ANNEX B - TECHNICAL CHECK LISTS.....</i> | <i>49</i> |
| 7.13 | <i>ANNEX C - TESTS REQUIRED FOR TECHNICAL CONFORMITY ASSESSMENT PROCESS</i> | <i>50</i> |
| 7.14 | <i>ANNEX D - REFERENTIAL DRAWINGS</i> | <i>52</i> |

THE HEAD OF Network Components
Maurizio Mazzotti



Technical Specification code: MAT-E&C-NC-2021-0057-EGIN
Version no. 0 dated 31/12/2021

Subject: Global Infrastructure and Networks – GSS004 –Glass Fiber Reinforced Polyester Poles for Distribution Network

Application Areas

Perimeter: *Global*

Staff Function: -

Service Function: -

Business Line: *Infrastructure & Networks*

1 DOCUMENT AIMS AND APPLICATION AREA

The scope of this document is to provide the technical requirements for the supply of glass fiber reinforced polyester poles (GFRP poles) to be used in the distribution networks of Enel Group Distribution Companies, listed below:

| Country | Distribution Company |
|-----------|--|
| Argentina | Edesur |
| Brazil | Enel Distribuição Rio Enel Distribuição Ceará Enel Distribuição Goiás Enel Distribuição São Paulo |
| Chile | Enel Distribución Chile |
| Colombia | Enel Codensa |
| Iberia | e-distribución |
| Italy | e-distribuzione |
| Peru | Enel Distribución Perú |
| Romania | Enel Distribuție Banat Enel Distribuție Dobrogea Enel Distribuție Muntenia |

Table 1 - Distribution Companies

This document specifies the characteristics and tests that shall be accomplished by the GFRP poles used in the low and medium voltage distribution network until rated voltage of 30 kV.

1.1 RELATED DOCUMENTS TO BE IMPLEMENTED AT COUNTRY LEVEL

This document applies to both Enel Global Infrastructure and Networks Srl Company and to Infrastructure and Networks Business Line perimeter when each Company does not have to issue further documents.



Technical Specification code: MAT-E&C-NC-2021-0057-EGIN
Version no. 0 dated 31/12/2021

Subject: Global Infrastructure and Networks – GSS004 –Glass Fiber Reinforced Polyester Poles for Distribution Network

Application Areas

Perimeter: *Global*

Staff Function: -

Service Function: -

Business Line: *Infrastructure & Networks*

2 DOCUMENT VERSION MANAGEMENT

| Revision | Data | List of modifications |
|----------|------------|-----------------------|
| 00 | 31/12/2021 | First emission. |

Table 2 Document version

3 UNITS IN CHARGE OF THE DOCUMENT

Responsible for drawing up the document:

- Global Infrastructure and Networks: Engineering and Construction / Components and Devices Design/ Network Components

Responsible for authorizing the document:

- Global Infrastructure and Networks: Head of Engineering and Construction unit
- Global Infrastructure and Networks: Head of Health, Safety, Environment and Quality unit.

4 REFERENCES

- Enel Group Code of Ethics;
- The Enel Group Zero Corruption Tolerance (ZCT) Plan;
- Organizational and management model as per Italian Legislative Decree no. 231/2001 or equivalent documents adopted in the Countries;
- Enel Human Rights Policy;
- Stop Work Policy;
- Enel Global Compliance Program (EGCP);
- Integrated Policy of Quality, Health and Safety, Environment and anti-Bribery;
- ISO 9001:2015 - Quality Management System - Requirements;
- ISO 14001:2015 - Environmental Management System - Requirements and user guide;
- ISO 45001:2018 - Occupational Health and Safety Management System - Requirements and user guide;
- ISO 50001:2018 - Energy management systems - Requirements with guidance for use;
- ISO 37001:2016 - Anti-bribery Management System - Requirements with guidance for use.
- MAT-O&M-NCS-2021-0033-EGIN version 3 “Global Infrastructure and Networks – GSCG002 Technical Conformity Assessment”.
- Contractual Requirements for Components and Materials Quality management.

Technical Specification code: MAT-E&C-NC-2021-0057-EGIN

Version no. 0 dated 31/12/2021

Subject: Global Infrastructure and Networks – GSS004 –Glass Fiber Reinforced Polyester Poles for Distribution Network

Application Areas
Perimeter: *Global*

Staff Function: -

Service Function: -

Business Line: *Infrastructure & Networks*

- CNS-O&M-S&L-2021-0032-EGIN “Global Infrastructure and Networks Barcode specification.
- Packaging, transport, and delivery requirements rev.2.

International technical references related with the material:

- IEC 60050. International Electrotechnical Vocabulary
- EN 40-7. Lighting columns - Part 7: Requirements for fibre reinforced polymer composite lighting columns
- EN ISO 62. Plastics — Determination of water absorption
- ASTM D570. Standard Test Method for Water Absorption of Plastics
- IEC 60695-11-10:2013. Fire hazard testing - Part 11-10: Test flames - 50 W horizontal and vertical flame test methods.
- ASTM D 635. Standard Test Method for Rate of Burning and/or Extent and Time of Burning of Plastics in a Horizontal Position
- EN ISO 1172. Textile-glass-reinforced plastics — Prepregs, moulding compounds and laminates — Determination of the textile-glass and mineral-filler content — Calcination methods
- ASTM D2734. Standard Test Methods for Void Content of Reinforced Plastics
- EN 59. Glass reinforced plastics. Determination of indentation hardness by means of a Barcol hardness tester
- ASTM D2583. Standard Test Method for Indentation Hardness of Rigid Plastics by Means of a Barcol Impressor
- EN ISO 527-1. Plastics — Determination of tensile properties — Part 1: General principles
- EN ISO 527-4. Plastics — Determination of tensile properties — Part 4: Test conditions for isotropic and orthotropic fibre-reinforced plastic composites
- EN ISO 14125. Fibre-reinforced plastic composites — Determination of flexural properties
- ASTM D790. Standard Test Methods for Flexural Properties of Unreinforced and Reinforced Plastics and Electrical Insulating Materials
- EN ISO 4892-2. Plastics — Methods of exposure to laboratory light sources — Part 2: Xenon-arc lamps
- ISO 4582. Plastics — Determination of changes in colour and variations in properties after exposure to glass-filtered solar radiation, natural weathering or laboratory radiation sources
- ASTM G154. Standard Practice for Operating Fluorescent Ultraviolet (UV) Lamp Apparatus for Exposure of Nonmetallic Materials
- ASTM G155. Standard Practice for Operating Xenon Arc Light Apparatus for Exposure of Non-Metallic Materials
- EN ISO 75-3. Plastics — Determination of temperature of deflection under load — Part 3: High-strength thermosetting laminates and long-fibre-reinforced plastics

Subject: Global Infrastructure and Networks – GSS004 –Glass Fiber Reinforced Polyester Poles for Distribution Network

Application Areas

Perimeter: *Global*

Staff Function: -

Service Function: -

Business Line: *Infrastructure & Networks*

- ASTM D648. Standard Test Method for Deflection Temperature of Plastics Under Flexural Load in the Edgewise Position
- IEC 60243-1. Electric strength of insulating materials - Test methods - Part 1: Tests at power frequencies
- ASTM D149. Standard Test Method for Dielectric Breakdown Voltage and Dielectric Strength of Solid Electrical Insulating Materials at Commercial Power Frequencies
- ISO 1183-1. Plastics - Methods for determining the density of non-cellular plastics - Part 1: Immersion method, liquid pycnometer method and titration method
- ASTM D792. Standard Test Methods for Density and Specific Gravity (Relative Density) of Plastics by Displacement
- EN 353-1. Personal fall protection equipment - Guided type fall arresters including an anchor line - Part 1: Guided type fall arresters including a rigid anchor line
- EN 353-2. Personal protective equipment against falls from a height - Part 2: Guided type fall arresters including a flexible anchor line.
- IEC 62262. Degrees of protection provided by enclosures for electrical equipment against external mechanical impacts (IK code)
- IEC 60587. Electrical insulating materials used under severe ambient conditions - Test methods for evaluating resistance to tracking and erosion
- ASTM D2303. Standard Test Methods for Liquid-Contaminant, Inclined-Plane Tracking and Erosion of Insulating Materials

Country laws

Argentina

- AEA95201 Asociación Electrotécnica Argentina: Reglamentación de líneas aéreas exteriores de baja tensión.
- AEA95301 Asociación Electrotécnica Argentina: Reglamentación de líneas aéreas exteriores de media y alta tensión.

Brazil

- NR-10 - Segurança em Instalações e Serviços em Eletricidade
- ABNT NBR 16989 Postes de poliéster reforçado com fibra de vidro (PRFV) para redes de distribuição eléctricas de até 36,2 kV- Especificação, métodos de ensaio, padronização e critérios de aceitação.

Colombia

- RETIE, Reglamento Técnico de Instalaciones Eléctricas

Technical Specification code: MAT-E&C-NC-2021-0057-EGIN

Version no. 0 dated 31/12/2021

Subject: Global Infrastructure and Networks – GSS004 –Glass Fiber Reinforced Polyester Poles for Distribution Network

Application Areas
Perimeter: *Global*

Staff Function: -

Service Function: -

Business Line: *Infrastructure & Networks*

Chile

- Reglamento de seguridad de las instalaciones eléctricas destinadas a la producción, transporte, prestación de servicios complementarios, sistemas de almacenamiento y distribución de energía eléctrica y todos sus Pliegos Técnicos

Perú

- CNE - Código Nacional de Electricidad – Suministro 2011

Italy

- D.Lgs n. 81 of the 9th of April 2008 and subsequent modifications.
- Nota Operativa PVR001 – Rev. 2 – Ott. 2012 - Gestione Garanzie dei materiali di ENEL Distribuzione.

Romania

- NTE 001/03/00 – Normativ privind alegerea izolației, coordonarea izolației și protecția instalațiilor electroenergetice împotriva supratensiunilor
- NTE 003/04/00 – Normativ pentru construcția liniilor electrice aeriene de energie electrică cu tensiuni peste 1000 V

Spain

- R.D. 614/2001, de 8 de junio, sobre disposiciones mínimas para la protección de la salud y seguridad de los trabajadores frente al riesgo eléctrico.
- R.D. 337/2014, de 9 de mayo, por el que se aprueban el Reglamento sobre condiciones técnicas y garantías de seguridad en instalaciones eléctricas de alta tensión y sus Instrucciones Técnicas Complementarias ITC-RAT 01 a 23.
- R.D. 223/2008, de 15 de febrero, por el que se aprueban el Reglamento sobre condiciones técnicas y garantías de seguridad en líneas eléctricas de alta tensión y sus instrucciones técnicas complementarias ITC-LAT 01 a 09.
- Real Decreto 842/2002, de 2 de agosto, por el que se aprueba el Reglamento electrotécnico para baja tensión.
- UNE 0059. Fiberglass reinforced polyester poles for overhead power distribution lines and telephony lines

Local replaced standards

- Argentina MAT-OMAR-NDS-20-0039-ESP
- Brazil MAT-OMBR-MAT-18-0047-EDBR/PM-BR 307.01



Technical Specification code: MAT-E&C-NC-2021-0057-EGIN

Version no. 0 dated 31/12/2021

Subject: Global Infrastructure and Networks – GSS004 –Glass Fiber Reinforced Polyester Poles for Distribution Network

Application Areas

Perimeter: *Global*

Staff Function: -

Service Function: -

Business Line: *Infrastructure & Networks*

- Colombia ET205
- Chile N/A
- Italy N/A
- Perú MAT-OYM-NDS-18-212-ESP
- Romania N/A
- Spain AND020

5 ORGANIZATIONAL PROCESS POSITION IN THE PROCESS TAXONOMY

Value Chain/Process Area: Networks Management

Macro Process: Materials management

Process: Network Components Standardization

6 DEFINITIONS AND ACRONYMS

The document has the following acronyms:

- GFRP pole: Glass fiber reinforced polyester pole (PRFV in Spanish and Portuguese)
- En: Nominal Design Load
- Er: Failure load
- H: Total length
- CS: Safety factor

Application Areas

Perimeter: *Global*
Staff Function: -
Service Function: -
Business Line: *Infrastructure & Networks*

7 DESCRIPTION

7.1 LIST OF COMPONENTS

| Global Type | Country | Country code | Designation | Nominal Design load, E _n [daN] | Safety factor | Failure load, E _r [daN] | Total length, H [m] | Cone taper [mm/m] | Cone taper tolerance [mm/m] | Top diameter [mm] | Base diameter (informative) [mm] | Number of sections | Colour | Top and butt cover colour | Coupling ring | J dimension [mm] | F dimension [mm] |
|-------------|---------|--------------|-----------------------------|---|---------------|------------------------------------|---------------------|-------------------|-----------------------------|-------------------|----------------------------------|--------------------|------------------|---------------------------|---------------|------------------|------------------|
| GSS004/01 | ES | 230334 | PRFV 120 - 10 - 132 | 120 | 2,5 | 300 | 10 | 18 | 1 | 132 | 312 | 1 | Brown (RAL 8025) | Grey (RAL 7032) | NO | NA | NA |
| GSS004/01 | ES | 230338 | PRFV 120 - 10 - 132 A(85) | 120 | 2,5 | 300 | 10 | 18 | 1 | 132 | 312 | 1 | Brown (RAL 8025) | Grey (RAL 7032) | TOP | NA | NA |
| GSS004/01 | ES | 230309 | PRFV 120 - 10 - 132 A(1190) | 120 | 2,5 | 300 | 10 | 18 | 1 | 132 | 312 | 1 | Brown (RAL 8025) | Grey (RAL 7032) | UNDER TOP | NA | NA |
| GSS004/02 | ES | 230304 | PRFV 250 - 11 - 150 | 250 | 2,5 | 625 | 11 | 18 | 1 | 150 | 348 | 1 | Brown (RAL 8025) | Black (RAL 7021) | NO | NA | NA |
| GSS004/02 | ES | 230303 | PRFV 250 - 11 - 150 A(85) | 250 | 2,5 | 625 | 11 | 18 | 1 | 150 | 348 | 1 | Brown (RAL 8025) | Black (RAL 7021) | TOP | NA | NA |
| GSS004/02 | ES | 230302 | PRFV 250 - 11 - 150 A(1190) | 250 | 2,5 | 625 | 11 | 18 | 1 | 150 | 348 | 1 | Brown (RAL 8025) | Black (RAL 7021) | UNDER TOP | NA | NA |
| GSS004/03 | ES | 230301 | PRFV 250 - 12 - 150 | 250 | 2,5 | 625 | 12 | 18 | 1 | 150 | 366 | 1 | Brown (RAL 8025) | Black (RAL 7021) | NO | NA | NA |
| GSS004/03 | ES | 230340 | PRFV 250 - 12 - 150 A(85) | 250 | 2,5 | 625 | 12 | 18 | 1 | 150 | 366 | 1 | Brown (RAL 8025) | Black (RAL 7021) | TOP | NA | NA |
| GSS004/03 | ES | 230299 | PRFV 250 - 12 - 150 A(1190) | 250 | 2,5 | 625 | 12 | 18 | 1 | 150 | 366 | 1 | Brown (RAL 8025) | Black (RAL 7021) | UNDER TOP | NA | NA |
| GSS004/04 | ES | 230298 | PRFV 250 - 13 - 150 | 250 | 2,5 | 625 | 13 | 18 | 1 | 150 | 384 | 2 | Brown (RAL 8025) | Black (RAL 7021) | NO | NA | NA |
| GSS004/04 | ES | 230297 | PRFV 250 - 13 - 150 A(85) | 250 | 2,5 | 625 | 13 | 18 | 1 | 150 | 384 | 2 | Brown (RAL 8025) | Black (RAL 7021) | TOP | NA | NA |
| GSS004/04 | ES | 230308 | PRFV 250 - 13 - 150 A(1190) | 250 | 2,5 | 625 | 13 | 18 | 1 | 150 | 384 | 2 | Brown (RAL 8025) | Black (RAL 7021) | UNDER TOP | NA | NA |
| GSS004/05 | CO | 230228 | PRFV 294 - 10 - 168 | 294 | 2,5 | 735 | 10 | 18 | 2 | 168 | 348 | 2 | Grey (RAL 7038) | Grey (RAL 7038) | NO | 1400 | 1300 |
| GSS004/06 | CO | 230227 | PRFV 294 - 12 - 168 | 294 | 2,5 | 735 | 12 | 18 | 2 | 168 | 384 | 2 | Grey (RAL 7038) | Grey (RAL 7038) | NO | 1600 | 3100 |
| GSS004/07 | CO | 230226 | PRFV 294 - 14 - 168 | 294 | 2,5 | 735 | 14 | 18 | 2 | 168 | 420 | 3 | Grey (RAL 7038) | Grey (RAL 7038) | NO | 1800 | 4900 |
| GSS004/08 | PE | 230111 | PRFV 300 - 8 - 168 | 300 | 2,5 | 750 | 8 | 18 | 2 | 168 | 312 | 1 | Grey (RAL 7038) | Grey (RAL 7038) | NO | 500 | 1200 |
| GSS004/09 | BR | 230213 | PRFV 300 - 10 - 165 | 300 | 2,5 | 750 | 10 | 18 | 2 | 165 | 345 | 2 | Grey (RAL 7038) | Grey (RAL 7038) | NO | 1100 | 975 |
| GSS004/10 | PE | 230121 | PRFV 300 - 10 - 168 | 300 | 2,5 | 750 | 10 | 18 | 2 | 168 | 348 | 1 | Grey (RAL 7038) | Grey (RAL 7038) | NO | 700 | 1200 |
| GSS004/10 | CL | 230234 | PRFV 300 - 10 - 168 | 300 | 2,5 | 750 | 10 | 18 | 2 | 168 | 348 | 2 | Grey (RAL 7038) | Grey (RAL 7038) | NO | 1400 | 2500 |
| GSS004/11 | PE | 230120 | PRFV 300 - 12 - 168 | 300 | 2,5 | 750 | 12 | 18 | 2 | 168 | 384 | 1 | Grey (RAL 7038) | Grey (RAL 7038) | NO | 900 | 1200 |
| GSS004/11 | AR | 0128-0031 | PRFV 300 - 12 - 168 | 300 | 2,5 | 750 | 12 | 18 | 2 | 168 | 384 | 2 | Grey (RAL 7038) | Grey (RAL 7038) | NO | 1600 | 500 |
| GSS004/12 | BR | 230212 | PRFV 300 - 12 - 170 | 300 | 2,5 | 750 | 12 | 18 | 2 | 170 | 386 | 2 | Grey (RAL 7038) | Grey (RAL 7038) | NO | 1300 | 2775 |
| GSS004/13 | CL | 230232 | PRFV 300 - 14 - 168 | 300 | 2,5 | 750 | 14 | 18 | 2 | 168 | 420 | 3 | Grey (RAL 7038) | Grey (RAL 7038) | NO | 1400 | 2500 |
| GSS004/13 | PE | 230117 | PRFV 300 - 14 - 168 | 300 | 2,5 | 750 | 14 | 18 | 2 | 168 | 420 | 2 | Grey (RAL 7038) | Grey (RAL 7038) | NO | 1700 | 200 |
| GSS004/14 | PE | 230113 | PRFV 300 - 16 - 168 | 300 | 2,5 | 750 | 16 | 18 | 2 | 168 | 456 | 2 | Grey (RAL 7038) | Grey (RAL 7038) | NO | 1900 | 200 |
| GSS004/15 | AR | 0128-0038 | PRFV 400 - 10 - 194 | 400 | 2,5 | 1000 | 10 | 18 | 2 | 194 | 374 | 2 | Grey (RAL 7038) | Grey (RAL 7038) | NO | 1400 | 500 |
| GSS004/16 | ES | 230237 | PRFV 400 - 11 - 190 | 400 | 2,5 | 1000 | 11 | 30 | 2 | 190 | 520 | 1 | Brown (RAL 8025) | Blue (RAL 5012) | NO | NA | NA |
| GSS004/16 | ES | 230256 | PRFV 400 - 11 - 190 A(85) | 400 | 2,5 | 1000 | 11 | 30 | 2 | 190 | 520 | 1 | Brown (RAL 8025) | Blue (RAL 5012) | TOP | NA | NA |
| GSS004/16 | ES | 230236 | PRFV 400 - 11 - 190 A(1190) | 400 | 2,5 | 1000 | 11 | 30 | 2 | 190 | 520 | 1 | Brown (RAL 8025) | Blue (RAL 5012) | UNDER TOP | NA | NA |

Application Areas

Perimeter: *Global*
Staff Function: -
Service Function: -
Business Line: *Infrastructure & Networks*

| Global Type | Country | Country code | Designation | Nominal Design load, E _n [daN] | Safety factor | Failure load, E _r [daN] | Total length, H [m] | Cone taper [mm/m] | Cone taper tolerance [mm/m] | Top diameter [mm] | Base diameter (informative) [mm] | Number of sections | Colour | Top and butt cover colour | Coupling ring | J dimension [mm] | F dimension [mm] |
|-------------|---------|--------------|-----------------------------|---|---------------|------------------------------------|---------------------|-------------------|-----------------------------|-------------------|----------------------------------|--------------------|------------------|---------------------------|---------------|------------------|------------------|
| GSS004/17 | AR | 0128-0037 | PRFV 400 - 12 - 194 | 400 | 2,5 | 1000 | 12 | 18 | 2 | 194 | 410 | 2 | Grey (RAL 7038) | Grey (RAL 7038) | NO | 1600 | 500 |
| GSS004/18 | ES | 230235 | PRFV 400 - 13 - 190 | 400 | 2,5 | 1000 | 13 | 30 | 2 | 190 | 580 | 2 | Brown (RAL 8025) | Blue (RAL 5012) | NO | NA | NA |
| GSS004/18 | ES | 230234 | PRFV 400 - 13 - 190 A(85) | 400 | 2,5 | 1000 | 13 | 30 | 2 | 190 | 580 | 2 | Brown (RAL 8025) | Blue (RAL 5012) | TOP | NA | NA |
| GSS004/18 | ES | 230233 | PRFV 400 - 13 - 190 A(1190) | 400 | 2,5 | 1000 | 13 | 30 | 2 | 190 | 580 | 2 | Brown (RAL 8025) | Blue (RAL 5012) | UNDER TOP | NA | NA |
| GSS004/19 | AR | 0128-0036 | PRFV 400 - 14 - 194 | 400 | 2,5 | 1000 | 14 | 18 | 2 | 194 | 446 | 3 | Grey (RAL 7038) | Grey (RAL 7038) | NO | 1800 | 500 |
| GSS004/20 | CO | 230225 | PRFV 412 - 10 - 194 | 412 | 2,5 | 1030 | 10 | 18 | 2 | 194 | 374 | 2 | Grey (RAL 7038) | Grey (RAL 7038) | NO | 1400 | 1300 |
| GSS004/21 | CO | 230224 | PRFV 412 - 12 - 194 | 412 | 2,5 | 1030 | 12 | 18 | 2 | 194 | 410 | 2 | Grey (RAL 7038) | Grey (RAL 7038) | NO | 1600 | 3100 |
| GSS004/22 | CO | 230223 | PRFV 412 - 14 - 194 | 412 | 2,5 | 1030 | 14 | 18 | 2 | 194 | 446 | 3 | Grey (RAL 7038) | Grey (RAL 7038) | NO | 1800 | 4900 |
| GSS004/23 | CO | 230222 | PRFV 412 - 16 - 194 | 412 | 2,5 | 1030 | 16 | 18 | 2 | 194 | 482 | 3 | Grey (RAL 7038) | Grey (RAL 7038) | NO | 1800 | 6900 |
| GSS004/24 | CO | 230218 | PRFV 530 - 12 - 221 | 530 | 2,5 | 1325 | 12 | 18 | 2 | 221 | 437 | 2 | Grey (RAL 7038) | Grey (RAL 7038) | NO | 1600 | 3100 |
| GSS004/25 | CO | 230217 | PRFV 530 - 14 - 221 | 530 | 2,5 | 1325 | 14 | 18 | 2 | 221 | 473 | 3 | Grey (RAL 7038) | Grey (RAL 7038) | NO | 1800 | 4900 |
| GSS004/26 | CO | 230216 | PRFV 530 - 16 - 221 | 530 | 2,5 | 1325 | 16 | 18 | 2 | 221 | 509 | 3 | Grey (RAL 7038) | Grey (RAL 7038) | NO | 1800 | 6900 |
| GSS004/27 | PE | 230118 | PRFV 600 - 8 - 238 | 600 | 2,5 | 1500 | 8 | 18 | 2 | 238 | 382 | 1 | Grey (RAL 7038) | Grey (RAL 7038) | NO | 500 | 1200 |
| GSS004/28 | BR | 230211 | PRFV 600 - 10 - 170 | 600 | 2,5 | 1500 | 10 | 18 | 2 | 170 | 350 | 2 | Grey (RAL 7038) | Grey (RAL 7038) | NO | 1100 | 975 |
| GSS004/29 | PE | 230122 | PRFV 600 - 10 - 238 | 600 | 2,5 | 1500 | 10 | 18 | 2 | 238 | 418 | 1 | Grey (RAL 7038) | Grey (RAL 7038) | NO | 700 | 1200 |
| GSS004/30 | BR | 230210 | PRFV 600 - 12 - 180 | 600 | 2,5 | 1500 | 12 | 18 | 2 | 180 | 396 | 2 | Grey (RAL 7038) | Grey (RAL 7038) | NO | 1300 | 2775 |
| GSS004/31 | PE | 230119 | PRFV 600 - 12 - 238 | 600 | 2,5 | 1500 | 12 | 18 | 2 | 238 | 454 | 1 | Grey (RAL 7038) | Grey (RAL 7038) | NO | 900 | 1200 |
| GSS004/31 | AR | 0128-0035 | PRFV 600 - 12 - 238 | 600 | 2,5 | 1500 | 12 | 18 | 2 | 238 | 454 | 2 | Grey (RAL 7038) | Grey (RAL 7038) | NO | 1600 | 500 |
| GSS004/32 | BR | 230209 | PRFV 600 - 14 - 238 | 600 | 2,5 | 1500 | 14 | 18 | 2 | 238 | 490 | 2 | Grey (RAL 7038) | Grey (RAL 7038) | NO | 1500 | 2775 |
| GSS004/32 | CL | 230231 | PRFV 600 - 14 - 238 | 600 | 2,5 | 1500 | 14 | 18 | 2 | 238 | 490 | 3 | Grey (RAL 7038) | Grey (RAL 7038) | NO | 1400 | 2500 |
| GSS004/32 | PE | 230115 | PRFV 600 - 14 - 238 | 600 | 2,5 | 1500 | 14 | 18 | 2 | 238 | 490 | 2 | Grey (RAL 7038) | Grey (RAL 7038) | NO | 1700 | 200 |
| GSS004/32 | AR | 0128-0034 | PRFV 600 - 14 - 238 | 600 | 2,5 | 1500 | 14 | 18 | 2 | 238 | 490 | 2 | Grey (RAL 7038) | Grey (RAL 7038) | NO | 1800 | 500 |
| GSS004/33 | PE | 230112 | PRFV 600 - 16 - 238 | 600 | 2,5 | 1500 | 16 | 18 | 2 | 238 | 526 | 2 | Grey (RAL 7038) | Grey (RAL 7038) | NO | 1900 | 200 |
| GSS004/34 | ES | 230079 | PRFV 630 - 11 - 250 | 630 | 2,5 | 1575 | 11 | 30 | 2 | 250 | 580 | 1 | Brown (RAL 8025) | Red (RAL 3000) | NO | NA | NA |
| GSS004/35 | ES | 230078 | PRFV 630 - 13 - 250 | 630 | 2,5 | 1575 | 13 | 30 | 2 | 250 | 640 | 2 | Brown (RAL 8025) | Red (RAL 3000) | NO | NA | NA |
| GSS004/36 | ES | 230077 | PRFV 630 - 15 - 250 | 630 | 2,5 | 1575 | 15 | 30 | 2 | 250 | 700 | 2 | Brown (RAL 8025) | Red (RAL 3000) | NO | NA | NA |
| GSS004/37 | AR | 0128-0033 | PRFV 800 - 10 - 280 | 800 | 2,5 | 2000 | 10 | 18 | 2 | 280 | 460 | 2 | Grey (RAL 7038) | Grey (RAL 7038) | NO | 1400 | 500 |
| GSS004/38 | ES | 230075 | PRFV 800 - 11 - 280 | 800 | 2,5 | 2000 | 11 | 30 | 2 | 280 | 610 | 1 | Brown (RAL 8025) | Yellow (RAL 1021) | NO | NA | NA |
| GSS004/39 | ES | 230023 | PRFV 800 - 13 - 280 | 800 | 2,5 | 2000 | 13 | 30 | 2 | 280 | 670 | 2 | Brown (RAL 8025) | Yellow (RAL 1021) | NO | NA | NA |
| GSS004/40 | PE | 230116 | PRFV 800 - 14 - 280 | 800 | 2,5 | 2000 | 14 | 18 | 2 | 280 | 532 | 2 | Grey (RAL 7038) | Grey (RAL 7038) | NO | 1700 | 200 |
| GSS004/40 | AR | 0128-0032 | PRFV 800 - 14 - 280 | 800 | 2,5 | 2000 | 14 | 18 | 2 | 280 | 532 | 3 | Grey (RAL 7038) | Grey (RAL 7038) | NO | 1800 | 500 |
| GSS004/41 | ES | 230341 | PRFV 800 - 15 - 280 | 800 | 2,5 | 2000 | 15 | 30 | 2 | 280 | 730 | 2 | Brown (RAL 8025) | Yellow (RAL 1021) | NO | NA | NA |
| GSS004/42 | PE | 230110 | PRFV 800 - 16 - 280 | 800 | 2,5 | 2000 | 16 | 18 | 2 | 280 | 568 | 2 | Grey (RAL 7038) | Grey (RAL 7038) | NO | 1900 | 200 |
| GSS004/43 | CL | 230233 | PRFV 1000 - 10 - 330 | 1000 | 2,5 | 2500 | 10 | 18 | 2 | 330 | 510 | 2 | Grey (RAL 7038) | Grey (RAL 7038) | NO | 1400 | 2500 |

Application Areas

Perimeter: *Global*
Staff Function: -
Service Function: -
Business Line: *Infrastructure & Networks*

| Global Type | Country | Country code | Designation | Nominal Design load, E _n [daN] | Safety factor | Failure load, E _r [daN] | Total length, H [m] | Cone taper [mm/m] | Cone taper tolerance [mm/m] | Top diameter [mm] | Base diameter (informative) [mm] | Number of sections | Colour | Top and butt cover colour | Coupling ring | J dimension [mm] | F dimension [mm] |
|-------------|---------|--------------|----------------------|---|---------------|------------------------------------|---------------------|-------------------|-----------------------------|-------------------|----------------------------------|--------------------|-----------------|---------------------------|---------------|------------------|------------------|
| GSS004/43 | BR | 230208 | PRFV 1000 - 10 - 330 | 1000 | 2,5 | 2500 | 10 | 18 | 2 | 330 | 510 | 2 | Grey (RAL 7038) | Grey (RAL 7038) | NO | 1100 | 975 |
| GSS004/44 | BR | 230207 | PRFV 1000 - 12 - 190 | 1000 | 2,5 | 2500 | 12 | 18 | 2 | 190 | 406 | 2 | Grey (RAL 7038) | Grey (RAL 7038) | NO | 1300 | 2775 |
| GSS004/45 | BR | 230206 | PRFV 1000 - 14 - 330 | 1000 | 2,5 | 2500 | 14 | 18 | 2 | 330 | 582 | 3 | Grey (RAL 7038) | Grey (RAL 7038) | NO | 1500 | 2775 |
| GSS004/46 | BR | 230126 | PRFV 1000 - 16 - 330 | 1000 | 2,5 | 2500 | 16 | 18 | 2 | 330 | 618 | 3 | Grey (RAL 7038) | Grey (RAL 7038) | NO | 1700 | 2775 |
| GSS004/47 | BR | 230125 | PRFV 2000 - 12 - 560 | 2000 | 2,5 | 5000 | 12 | 18 | 2 | 560 | 776 | 2 | Grey (RAL 7038) | Grey (RAL 7038) | NO | 1300 | 2775 |
| GSS004/48 | BR | 230127 | PRFV 2000 - 14 - 560 | 2000 | 2,5 | 5000 | 14 | 18 | 2 | 560 | 812 | 3 | Grey (RAL 7038) | Grey (RAL 7038) | NO | 1500 | 2775 |
| GSS004/48 | CL | 230230 | PRFV 2000 - 14 - 560 | 2000 | 2,5 | 5000 | 14 | 18 | 2 | 560 | 812 | 3 | Grey (RAL 7038) | Grey (RAL 7038) | NO | 1400 | 2500 |
| GSS004/48 | PE | 230114 | PRFV 2000 - 14 - 560 | 2000 | 2,5 | 5000 | 14 | 18 | 2 | 560 | 812 | 2 | Grey (RAL 7038) | Grey (RAL 7038) | NO | 1700 | 200 |
| GSS004/49 | BR | 230124 | PRFV 2000 - 16 - 560 | 2000 | 2,5 | 5000 | 16 | 18 | 2 | 560 | 848 | 3 | Grey (RAL 7038) | Grey (RAL 7038) | NO | 1700 | 2775 |
| GSS004/49 | CL | 230229 | PRFV 2000 - 16 - 560 | 2000 | 2,5 | 5000 | 16 | 18 | 2 | 560 | 848 | 3 | Grey (RAL 7038) | Grey (RAL 7038) | NO | 1400 | 2500 |
| GSS004/49 | PE | 230109 | PRFV 2000 - 16 - 560 | 2000 | 2,5 | 5000 | 16 | 18 | 2 | 560 | 848 | 2 | Grey (RAL 7038) | Grey (RAL 7038) | NO | 1900 | 200 |
| GSS004/50 | PE | 230108 | PRFV 2000 - 20 - 560 | 2000 | 2,5 | 5000 | 20 | 18 | 2 | 560 | 920 | 3 | Grey (RAL 7038) | Grey (RAL 7038) | NO | 2300 | 200 |
| GSS004/51 | BR | 230123 | PRFV 3000 - 12 - 791 | 3000 | 2,5 | 7500 | 12 | 18 | 2 | 791 | 1007 | 2 | Grey (RAL 7038) | Grey (RAL 7038) | NO | 1300 | 2775 |
| GSS004/52 | CL | 230235 | PRFV 3000 - 14 - 791 | 3000 | 2,5 | 7500 | 14 | 18 | 2 | 791 | 1043 | 3 | Grey (RAL 7038) | Grey (RAL 7038) | NO | 1400 | 2500 |

NOTES: Tolerance for total height H (-0; +5 mm)
Tolerance for top diameter ±5 mm. In Colombia it could be accepted ±10 mm
F and J values could be requested in the future in the countries that had no values currently defined
Mass is not included as a requirement, but it shall be informed in data sheet

Table 3 Glass fiber reinforced polyester poles for distribution lines



Subject: Global Infrastructure and Networks – GSS004 –Glass Fiber Reinforced Polyester Poles for Distribution Network

Application Areas

Perimeter: *Global*

Staff Function: -

Service Function: -

Business Line: *Infrastructure & Networks*

7.2 SERVICE CONDITIONS

Poles for distribution networks shall be suitable to operate in outdoor environments in the different countries where Enel operates:

- Maximum Ambient Air Temperature: + 50 °C.
- Minimum Ambient Air Temperature: - 40 °C.
- Maximum relative humidity: 100%.
- Maximum height, 2.700 m.
- Maximum solar radiation: 1.000 W/m²

For seismic requirement, the following table applies:

| Seismic requirements | |
|----------------------|--|
| Chile | Document ETG1020 |
| Peru | E.030 NORMA TECNICA DISEÑO SISMORESISTENTE |
| Colombia | NSR010 |

Table 4 Seismic requirement

7.3 TECHNICAL CHARACTERISTICS

7.3.1 Electrical behavior

The GFRP poles shall be made of a non-conductive material of electricity. It shall be required a minimum dielectric strength of 5 kV/mm for the pole material.

7.3.2 Mechanical Load and Safety Factor

Considering the Design Load, E_n , as the load which all elements should just sustain without failure, during any specified duration and the Failure Load, E_r , as the load which causes failure to occur in any element, we can define the Safety Factor, CS, as the relation between the Failure Load and Design load¹:

¹ Note that sometimes in Colombia it is commonly used the expression Carga de diseño referred to Failure Load- E_r - and Carga de trabajo to Design load- E_n . Please, be careful as this specification will work the concepts defined in English.

Technical Specification code: MAT-E&C-NC-2021-0057-EGIN

Version no. 0 dated 31/12/2021

Subject: Global Infrastructure and Networks – GSS004 –Glass Fiber Reinforced Polyester Poles for Distribution Network

Application Areas
Perimeter: *Global*

Staff Function: -

Service Function: -

Business Line: *Infrastructure & Networks*

$$CS = \frac{E_r}{E_n}$$

Poles shall be defined with the Design Load. It shall be considered a Safety Factor of 2,5 for the calculation of the Failed Load. The load case for testing shall be considered based upon the Failure Loads applied perpendicularly to the longitudinal pole axis at a distance “d” from the top of the pole and including the wind effect as described in Tables 5 and 6.

Note that the safety factor shall be 2,5, except for torsion load, where applies $CS = 2$.

In order to apply the loads, it will be considered a theoretical ground line positioned at “0,1H + 0,6”, as explained below, “GFRP Pole General Design” (the theoretical ground line is positioned at 01H+0,5 in Spain poles).

See table 5 with the load application point and the wind speed to be considered and table 6 with the load case:

| Country | Distance "d" from top of the pole Loads application point [mm] | Wind speed [km/h] |
|-----------|--|----------------------|
| Argentina | 100 | 145 |
| Brazil | 100 | 145 |
| Colombia | 100 | 145 |
| Chile | 100 | 145 |
| España | 250 | 120 |
| Perú | 100 | 94 |

Table 5 Load Application Point and wind speed



Subject: Global Infrastructure and Networks – GSS004 –Glass Fiber Reinforced Polyester Poles for Distribution Network

Application Areas

Perimeter: *Global*

Staff Function: -

Service Function: -

Business Line: *Infrastructure & Networks*

| Design load (daN) | Design load + overload (daN) | | | Safety factor (-) | Failure load (to be tested) (daN) | | |
|----------------------|---------------------------------|-------------------------|-----------------|----------------------|--------------------------------------|----------------------------|------------------|
| | V ¹⁾ | (M o S)+W ²⁾ | T ³⁾ | | V' ¹⁾ | (M' o S')+W' ²⁾ | T' ³⁾ |
| 120 | 300 | 120 + W | - | 2,5 | 750 | 300 + W' | - |
| | 300 | - | 92 | 2 | 600 | - | 184 |
| 250 | 300 | 250 + W | - | 2,5 | 750 | 625 + W' | - |
| | 300 | - | 192 | 2 | 600 | - | 384 |
| 300 | 300 | 300 + W | - | 2,5 | 750 | 750 + W' | - |
| | 300 | - | 230 | 2 | 600 | - | 460 |
| 400 | 700 | 400 + W | - | 2,5 | 1.750 | 1.000 + W' | - |
| | 700 | - | 308 | 2 | 1.400 | - | 616 |
| 412 | 700 | 412 + W | - | 2,5 | 1.750 | 1.000 + W' | - |
| | 700 | - | 317 | 2 | 1.400 | - | 634 |
| 530 | 750 | 530 + W | - | 2,5 | 1.875 | 1.325 + W' | - |
| | 750 | - | 408 | 2 | 1.500 | - | 816 |
| 600 | 750 | 600 + W | - | 2,5 | 1.875 | 1.500 + W' | - |
| | 750 | - | 462 | 2 | 1.500 | - | 924 |
| 630 | 750 | 630 + W | - | 2,5 | 1.875 | 1.575 + W' | - |
| | 750 | - | 485 | 2 | 1.500 | - | 970 |
| 800 | 800 | 800 + W | - | 2,5 | 2.000 | 2.000 + W' | - |
| | 800 | - | 615 | 2 | 1.600 | - | 1.230 |
| 1000 | 1750 | 1.000 + W | - | 2,5 | 4.375 | 2.500 + W' | - |
| | 1750 | - | 667 | 2 | 3.500 | - | 1.334 |
| 1250 | 1750 | 1.250 + W | - | 2,5 | 4.375 | 3.125 + W' | - |
| | 1750 | - | 838 | 2 | 3.500 | - | 1.676 |
| 1600 | 1750 | 1.600 + W | - | 2,5 | 4.375 | 4.000 + W' | - |
| | 1750 | - | 1.067 | 2 | 3.500 | - | 2.134 |
| 2000 | 1750 | 2.000 + W | - | 2,5 | 4.375 | 5.000 + W' | - |
| | 1750 | - | 1.329 | 2 | 3.500 | - | 2658 |
| 2500 | 1750 | 2.500 + W | - | 2,5 | 4.375 | 6.250 + W' | - |
| | 1750 | - | 1.650 | 2 | 3.500 | - | 3.300 |
| 3000 | 1750 | 3.000 + W | - | 2,5 | 4.375 | 7.500 + W' | - |
| | 1750 | - | 1.978 | 2 | 3.500 | - | 3.956 |

¹⁾ V and V' loads applied on the top of the pole in the direction of the pole axis.

²⁾ M/M' or S/S' loads applied horizontally at distance d under the top of the pole. It shall be added the overload (W) produced by the wind over the pole considering wind effect. Wind load will also be multiplied by the Safety factor.

³⁾ T and T' loads applied perpendicular to the axis pole, at distance d under the top of the pole, at 1500 mm from the pole axis.

Table 6 Load case

Subject: Global Infrastructure and Networks – GSS004 –Glass Fiber Reinforced Polyester Poles for Distribution Network

Application Areas

Perimeter: *Global*
Staff Function: -
Service Function: -
Business Line: *Infrastructure & Networks*

7.3.3 Maximum Sag admitted

Loads applied on the pole produce a sag, this standard specifies a Maximum Sag when the pole is loaded, furthermore, once the loads disappear, there is a remaining sag. Both sags (maximum and remaining) shall be as defined in the following table:

| Power poles | |
|--|---|
| Maximum sag when the pole is loaded ¹ [% about the length over the ground ²] | Remaining sag when load withdrawn [% about the length over the ground ²] |
| 5 | 1 |

Table 7 Maximum and remaining sag

(1) *Including wind load.*

(2) *Length over the ground obtained as the difference between total length and the theoretical ground line described below.*

7.4 CONSTRUCTION CHARACTERISTICS

7.4.1 GFRP Pole General Design

This standard considers an only type of fiber- glass polyester reinforced pole according shape:

| | Shape |
|------------------|--|
| Type C, circular | Circular base and top, constant cone taper |

Table 8 Types of poles

Type C consists of a pole with round section and constant cone taper all along. It could be produced in one only section or, for bigger lengths, in different sections to be coupled in order to make it easy to handle.

Subject: Global Infrastructure and Networks – GSS004 –Glass Fiber Reinforced Polyester Poles for Distribution Network

Application Areas

Perimeter: *Global*

Staff Function: -

Service Function: -

Business Line: *Infrastructure & Networks*

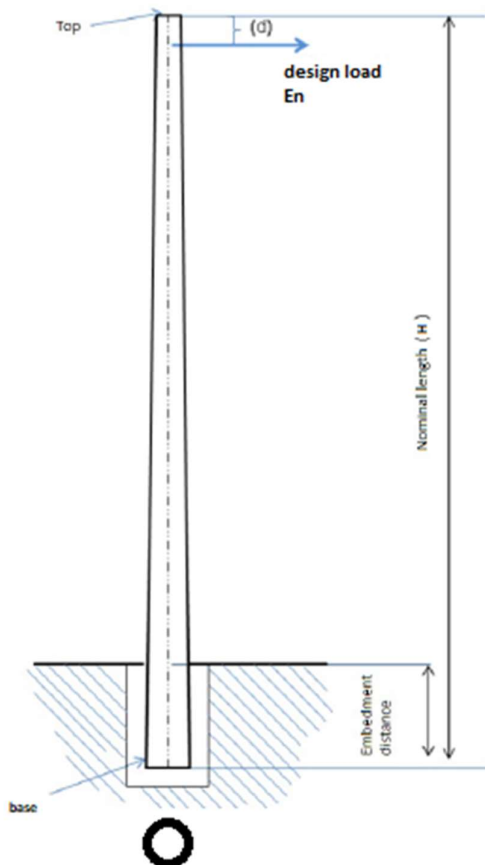

Image 1 General design

In case the pole is built in different sections, each one shall be 11 m long as maximum. The number of sections per pole is defined in table 3. Each section shall be able to be transported by a team without the help of any additional machinery. The coupling of different sections shall be guaranteed without the need of any additional system, but in case this is not possible, Enel could evaluate additional locking systems.

Total length, base and top dimensions and number of sections for each Country code are informed in table 3 in addition to other information.

The total length (H) is defined from the basis to the top of the pole, although for tests it will be considered a theoretical ground line at “ $0,1H + 0,6$ ”, except for Spain, where it will be considered at “ $0.1H + 0,5$ ”. H is expressed in m.

7.4.2 Pole Straightness

GFRP poles shall be as straight as possible, being admitted a tolerance of 0,15%.

Subject: Global Infrastructure and Networks – GSS004 –Glass Fiber Reinforced Polyester Poles for Distribution Network

Application Areas

Perimeter: *Global*

Staff Function: -

Service Function: -

Business Line: *Infrastructure & Networks*

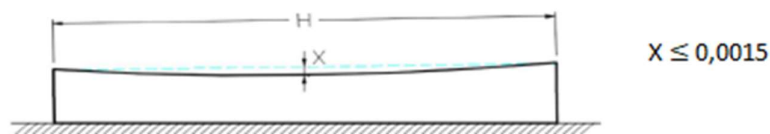

Image 2 Straightness tolerance

7.4.3 Drill holes

GFRP poles shall present some drill holes for different uses (accessories and fittings including holes for the installation of a lifeline) disposed in the main and secondary direction as requested for each country.

Usually, the Main Direction or Cross Direction is defined as the direction perpendicular to the axis pole, this is the perpendicular direction to the overhead line. The Secondary direction or longitudinal direction is the perpendicular direction to the axis pole and perpendicular to the main direction (longitudinal direction to the overhead line)

The holes shall have a good finish, without burrs and with its edges sealed with the same resin. They shall be sealed prior to receive any other finishing layer. The holes shall support the fittings and accessories used in the line and for the maintenance.

Those holes shall have removable taps made of synthetic material resistant to outdoor conditions, UV radiation and with the same expected lifetime than the pole. The taps shall be able to resist transport, manipulation and the effect of the wind.

7.4.3.1 Fixation of accessories

Poles shall have different drill holes in two perpendicular planes coinciding with main and secondary direction.

The diameter of the holes and the position to be placed are defined in the table below:

Technical Specification code: MAT-E&C-NC-2021-0057-EGIN

Version no. 0 dated 31/12/2021

Subject: Global Infrastructure and Networks – GSS004 –Glass Fiber Reinforced Polyester Poles for Distribution Network

Application Areas
Perimeter: *Global*

Staff Function: -

Service Function: -

Business Line: *Infrastructure & Networks*

| Country | Nominal load [daN] | Height [m] | Hole diameter [mm] | Distance hole axis to the top Tolerance ± 1 mm [mm] | |
|----------|---------------------|-------------|--------------------|---|--|
| | | | | Main direction | Secondary direction |
| Spain | 120 to 250 | | 17,5 \pm 0,5 | 127, 297, 600, 722, 900, 1232, 1827 | 85, 255, 680, 1190, 1785 |
| Spain | 400 to 2000 | | 17,5 \pm 0,5 | 127, 212, 297, 467, 637, 807, 977, 1147, 1317, 1487, 1657, 1827, 1997, 2167, 2337 | 85, 170, 340, 510, 680, 850, 1020, 1190, 1360, 1530, 1700, 1870, 2040, 2210, 2380 |
| PERU | 300, 600 | 8, 10,12 | 20,0 \pm 0,5 | 400, 600, 800 | 300, 500 |
| PERU | 300, 600, 800, 2000 | 14, 16, 20 | 22,0 \pm 0,5 | 300, 500, 700, 900, 1100, 1300, 1500, 1700, 1900, 2300, 2500,3100, 3400 | 600, 1000, 1400, 1600, 1800, 2200, 2600, 3200, 3400 |
| Colombia | - | 10 | 20,0 \pm 0,5 | 100, 300, 500, 700, 900, 1100 | |
| Colombia | - | 12, | 20,0 \pm 0,5 | 100, 300, 500, 700, 900, 1100, 1300, 1900, 2100, 2300, 2500, 2700, 2900 | |
| Colombia | - | 14 | 20,0 \pm 0,5 | 100, 300, 500, 700, 900, 1100, 1300, 3700, 3900, 4100, 4300, 4500, 4700 | |
| Colombia | - | 16 | 20,0 \pm 0,5 | 100, 300, 500, 700, 900, 1100, 1300, 5700, 5900, 6100, 6300, 6500, 6700 | |
| Chile | - | 10-12-14-16 | 22,0 \pm 0, | 200, 600, 800, 1200, 1500, 1800, 2100, 2350, 2650, 2950, 3250, 3550, 3850, 4150, 4450 | 150, 350, 750, 950, 1350, 1950, 2400, 2700, 3000, 3300, 3600, 3900, 4200, 4600, 5950, 7150, 7750 |

Table 9 Holes for accessories
7.4.3.2 Lifeline

The pole shall have through holes in the secondary direction to install a lifeline. The holes shall have a diameter of 17,5 \pm 0,5 mm and they will be placed according to the tables below:

Technical Specification code: MAT-E&C-NC-2021-0057-EGIN

Version no. 0 dated 31/12/2021

Subject: Global Infrastructure and Networks – GSS004 –Glass Fiber Reinforced Polyester Poles for Distribution Network

Application Areas
Perimeter: *Global*

Staff Function: -

Service Function: -

Business Line: *Infrastructure & Networks*

| Nominal load [daN] | Hole diameter [mm] | Distance from the hole axis to the top [m] | | | | |
|--------------------|--------------------|--|-----------------|-----------------------|---------------------------|-------------------------------------|
| | | H = 8 and 9 m | H = 10 and 11 m | H = 12 to 14 m | H = 15 and 16 m | H = 17 to 21 m |
| 120 to 250 | 17,5 ± 0,5 | 3 | 3 - 5 | 3 - 7 | - | - |
| 400 to 2000 | 17,5 ± 0,5 | 3 | 3 - 4 - 5 - 6 | 3 - 4 - 5 - 6 - 7 - 8 | 3 - 4 - 5 - 6 - 7 - 8 - 9 | 3 - 4 - 5 - 6 - 7 - 8 - 9 - 10 - 11 |

Table 10 Secondary direction: Holes to install a lifeline

When the lifeline hole coincides with the coupling of two sections, the hole shall be done just over the coupling zone.

When a lifeline hole coincides with an accessory hole or the distance between them is less than 400mm, it will remain the accessory hole, being the lifeline hole eliminated.

7.4.3.3 System to climb

This section applies only to Spain.

The pole shall be climbed through removable step bolts to be installed in drill holes with diameter 21 mm and distributed each 500 mm in the right faces so that makes it easy to climb.

The drill holes shall begin over the first 2,5 m from the theoretical ground line and follow until the last 500 mm below the last hole for accessories (avoiding the fitting zone of two sections).

7.4.3.4 Additional hole for grounding conductor

Two additional holes are required to install the conductor used in the grounding system. It is positioned at a distance J from the basis and F from the top (see table 3).

Argentina, Brazil and Chile use an oblong hole as defined below:

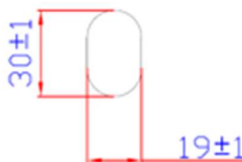
Image 3 Oblong hole for power supply, dimensions in mm

For Colombia and Perú the hole shall be round shaped with a diameter of 30 mm ± 1 mm.

7.4.4 Pole covers

The GFRP shall be constructed with not removable covers in top and base. Covers shall be in the same material of the pole and they shall perfectly fit to the top and butt, not exceeding its diameter. The upper cover is not

Subject: Global Infrastructure and Networks – GSS004 –Glass Fiber Reinforced Polyester Poles for Distribution Network

Application Areas

Perimeter: *Global*

Staff Function: -

Service Function: -

Business Line: *Infrastructure & Networks*

allowed to stand out the pole. Covers shall be able to resist the transport, the manipulation and, once in field, the effect of the wind.

In some cases, covers shall have a different colour to represent the load, as shown in table 3.

7.4.5 Coupling ring: Support for crossarm fixation

Poles could be requested with a special support, called coupling ring that serves to fix a crossarm to a circular pole.

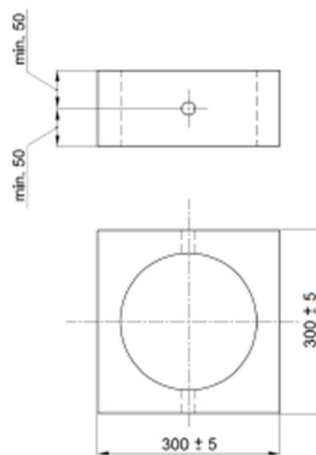

Image 4 Coupling ring for poles till 630 daN. Dimensions (in mm)

The coupling ring shall be internally circumscribed to the pole and externally square shaped, with faces aligned to the main and secondary direction. The ring is designed to couple the pole at a determined distance from the top (coupling distance) so that the hole in the coupling ring shall coincide with the hole for the accessory in the pole (holes at 85 mm or 1190 mm from the top in the secondary direction).

Subject: Global Infrastructure and Networks – GSS004 –Glass Fiber Reinforced Polyester Poles for Distribution Network

Application Areas

Perimeter: *Global*

Staff Function: -

Service Function: -

Business Line: *Infrastructure & Networks*

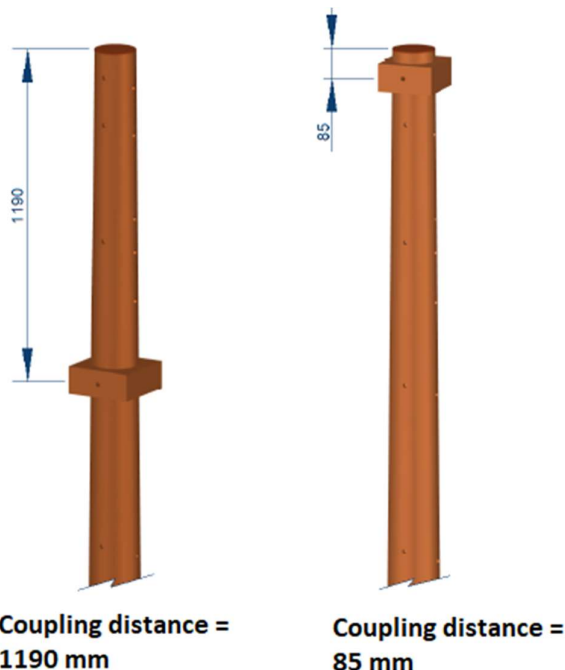

Image 5 Poles with coupling rings at coupling distance of 85 and 1190 mm

The coupling rings shall be solid, and it shall be joined to the pole being both pieces as one. The ring shall resist the torsion test.

Other solutions according to the current legislation of each country could be considered.

7.4.6 Pole material

The poles described in this standard shall be made of a thermoset polymeric material reinforced with glass fiber capable of supporting the mechanical load requested.

7.4.6.1 Polymeric resin

It is required the use of thermosetting isophthalic polyester with the characteristics listed in EN 40-7 (Annex A, point A.4, Table A.3):

| <i>Property</i> | <i>Value</i> |
|------------------------------------|--------------|
| Tensile modulus | 3,4 Gpa |
| Tensile strength | 79 Mpa |
| Ultimate elongation | 3,50% |
| Barcol hardness | 43 |
| Deformation temperature under load | 78 °C |

Table 11 Characteristics for the polymeric resin (polyester)



Technical Specification code: MAT-E&C-NC-2021-0057-EGIN

Version no. 0 dated 31/12/2021

Subject: Global Infrastructure and Networks – GSS004 –Glass Fiber Reinforced Polyester Poles for Distribution Network

Application Areas

Perimeter: *Global*

Staff Function: -

Service Function: -

Business Line: *Infrastructure & Networks*

Based upon technical reports including the appropriate tests, Enel would evaluate other additional or alternative resins with equivalent or better characteristics than the thermosetting polyester.

The pole supplier shall verify the technical requirements for each resin batch.

7.4.6.2 Additives for the polymeric resin

Additives shall be added to resin in order to guarantee the resin stability in confront to UV, so to minimize the material degradation and the loss of color through the pole lifetime. Veils with the same purpose could be accepted, as an alternative or a complement to additives so to improve the behavior to UV radiation.

Additives shall be added to resin to achieve a better behavior to fire.

All the additives shall be non-toxic for humans and the environment and allowed in all countries according to international regulation.

Subject: Global Infrastructure and Networks – GSS004 –Glass Fiber Reinforced Polyester Poles for Distribution Network

Application Areas
Perimeter: *Global*

Staff Function: -

Service Function: -

Business Line: *Infrastructure & Networks*

7.4.6.3 Glass fiber reinforce

The glass fiber used to reinforce the resin shall be “E” type according EN 40-7_Annex A:

| <i>Fiber shape</i> | Round fibers with diameter between 15 µm and 20 µm | | | | | | | | | | | | | | | | | | | | | | | | | | | | | | | | | | | | | | | | | | | | | | | | | | | | | | | | |
|---------------------------------|---|-------------|--------------|-------------|-------------|--------------|---|---|----|----|---|---|----|----|---|----|----|----|---|----|----|----|---|----|----|----|---|----|----|----|---|----|----|----|---|----|----|----|---|----|----|----|---|----|----|----|----|----|----|----|----|----|----|----|----|---|----|
| <i>Typical composition</i> | Molecule | Percentage | | | | | | | | | | | | | | | | | | | | | | | | | | | | | | | | | | | | | | | | | | | | | | | | | | | | | | | |
| | SiO ₂ | 54 | | | | | | | | | | | | | | | | | | | | | | | | | | | | | | | | | | | | | | | | | | | | | | | | | | | | | | | |
| | Al ₂ O ₃ | 15 | | | | | | | | | | | | | | | | | | | | | | | | | | | | | | | | | | | | | | | | | | | | | | | | | | | | | | | |
| | CaO - MgO | 22 | | | | | | | | | | | | | | | | | | | | | | | | | | | | | | | | | | | | | | | | | | | | | | | | | | | | | | | |
| | B ₂ O ₃ | 6,5 | | | | | | | | | | | | | | | | | | | | | | | | | | | | | | | | | | | | | | | | | | | | | | | | | | | | | | | |
| <i>Typical properties</i> | Tensile modulus | 72 Gpa | | | | | | | | | | | | | | | | | | | | | | | | | | | | | | | | | | | | | | | | | | | | | | | | | | | | | | | |
| | Tensile strength | 1.500 Mpa | | | | | | | | | | | | | | | | | | | | | | | | | | | | | | | | | | | | | | | | | | | | | | | | | | | | | | | |
| <i>Corrosion of glass fiber</i> | Tensile strength retained with pH | | | | | | | | | | | | | | | | | | | | | | | | | | | | | | | | | | | | | | | | | | | | | | | | | | | | | | | | |
| |  <table border="1"> <caption>Data for Table 12 "E" fiber characteristics - Tensile strength retained (%) vs pH</caption> <thead> <tr> <th>pH</th> <th>Glass E (%)</th> <th>Glass R (%)</th> <th>Glass AR (%)</th> </tr> </thead> <tbody> <tr><td>0</td><td>0</td><td>60</td><td>60</td></tr> <tr><td>1</td><td>0</td><td>60</td><td>60</td></tr> <tr><td>2</td><td>15</td><td>58</td><td>62</td></tr> <tr><td>3</td><td>30</td><td>55</td><td>64</td></tr> <tr><td>4</td><td>40</td><td>53</td><td>66</td></tr> <tr><td>5</td><td>50</td><td>51</td><td>68</td></tr> <tr><td>6</td><td>65</td><td>50</td><td>70</td></tr> <tr><td>7</td><td>65</td><td>48</td><td>70</td></tr> <tr><td>8</td><td>25</td><td>48</td><td>70</td></tr> <tr><td>9</td><td>25</td><td>52</td><td>72</td></tr> <tr><td>10</td><td>25</td><td>62</td><td>74</td></tr> <tr><td>11</td><td>20</td><td>70</td><td>75</td></tr> <tr><td>12</td><td>0</td><td>50</td><td>5</td></tr> </tbody> </table> | | pH | Glass E (%) | Glass R (%) | Glass AR (%) | 0 | 0 | 60 | 60 | 1 | 0 | 60 | 60 | 2 | 15 | 58 | 62 | 3 | 30 | 55 | 64 | 4 | 40 | 53 | 66 | 5 | 50 | 51 | 68 | 6 | 65 | 50 | 70 | 7 | 65 | 48 | 70 | 8 | 25 | 48 | 70 | 9 | 25 | 52 | 72 | 10 | 25 | 62 | 74 | 11 | 20 | 70 | 75 | 12 | 0 | 50 |
| pH | Glass E (%) | Glass R (%) | Glass AR (%) | | | | | | | | | | | | | | | | | | | | | | | | | | | | | | | | | | | | | | | | | | | | | | | | | | | | | | |
| 0 | 0 | 60 | 60 | | | | | | | | | | | | | | | | | | | | | | | | | | | | | | | | | | | | | | | | | | | | | | | | | | | | | | |
| 1 | 0 | 60 | 60 | | | | | | | | | | | | | | | | | | | | | | | | | | | | | | | | | | | | | | | | | | | | | | | | | | | | | | |
| 2 | 15 | 58 | 62 | | | | | | | | | | | | | | | | | | | | | | | | | | | | | | | | | | | | | | | | | | | | | | | | | | | | | | |
| 3 | 30 | 55 | 64 | | | | | | | | | | | | | | | | | | | | | | | | | | | | | | | | | | | | | | | | | | | | | | | | | | | | | | |
| 4 | 40 | 53 | 66 | | | | | | | | | | | | | | | | | | | | | | | | | | | | | | | | | | | | | | | | | | | | | | | | | | | | | | |
| 5 | 50 | 51 | 68 | | | | | | | | | | | | | | | | | | | | | | | | | | | | | | | | | | | | | | | | | | | | | | | | | | | | | | |
| 6 | 65 | 50 | 70 | | | | | | | | | | | | | | | | | | | | | | | | | | | | | | | | | | | | | | | | | | | | | | | | | | | | | | |
| 7 | 65 | 48 | 70 | | | | | | | | | | | | | | | | | | | | | | | | | | | | | | | | | | | | | | | | | | | | | | | | | | | | | | |
| 8 | 25 | 48 | 70 | | | | | | | | | | | | | | | | | | | | | | | | | | | | | | | | | | | | | | | | | | | | | | | | | | | | | | |
| 9 | 25 | 52 | 72 | | | | | | | | | | | | | | | | | | | | | | | | | | | | | | | | | | | | | | | | | | | | | | | | | | | | | | |
| 10 | 25 | 62 | 74 | | | | | | | | | | | | | | | | | | | | | | | | | | | | | | | | | | | | | | | | | | | | | | | | | | | | | | |
| 11 | 20 | 70 | 75 | | | | | | | | | | | | | | | | | | | | | | | | | | | | | | | | | | | | | | | | | | | | | | | | | | | | | | |
| 12 | 0 | 50 | 5 | | | | | | | | | | | | | | | | | | | | | | | | | | | | | | | | | | | | | | | | | | | | | | | | | | | | | | |

Table 12 “E” fiber characteristics

Based upon technical reports including the appropriate tests, Enel would evaluate other additional or alternative glass fiber with equivalent or better characteristics.

The pole supplier shall verify the technical requirements for each fiber batch.

7.4.7 Colour of the pole

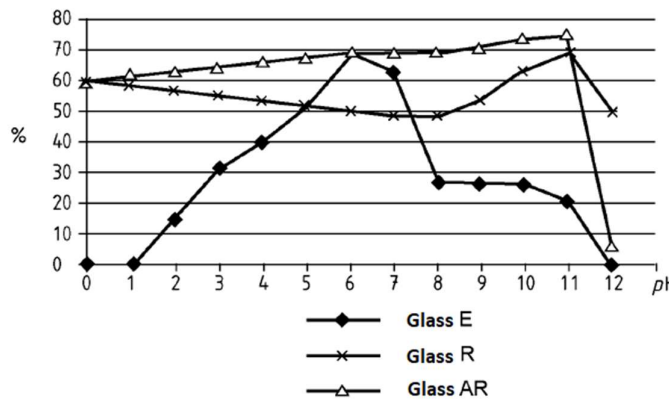
The pole shall be coloured in mass with a pigment according to the colour requested in table 3, with no need of an additional paint layer.

Previously consulted, another colour could be requested by Enel.



Technical Specification code: MAT-E&C-NC-2021-0057-EGIN
Version no. 0 dated 31/12/2021

Subject: Global Infrastructure and Networks – GSS004 –Glass Fiber Reinforced Polyester Poles for Distribution Network

Application Areas

Perimeter: *Global*

Staff Function: -

Service Function: -

Business Line: *Infrastructure & Networks*

7.4.8 Resistance to fire

The pole shall be classified as V-0 according the vertical test from IEC 60695-11-10.

7.4.9 Resistance to impacts

The pole shall be classified as IK-10 according the vertical test from IEC 62262.

7.4.10 Material thickness

The nominal thickness of the pole wall informed by the supplier shall have a tolerance of -1mm in the average of 8 measures of any cross section, being all individuals greater than the 90% of the nominal thickness.

7.4.11 Surface finishing

The outer surface of the pole shall be smooth and free of any kind of defect as blisters, burns, cavities, deformation, loss of material or shrinkage, wrinkles, cracks, appearing fiber, peeling or any other which could compromise its functionality, durability or aesthetics.

The outer part of the pole and its covers shall be free of fiber for a minimum thickness of 0,2 mm, creating a layer formed only by the polymeric resin (with the additives and the veil if any).

The outer surface of the pole shall have an anti-slip finishing to make easier the grabbing in the ground or the foundation and the climbing.

7.4.12 Pole mass

Mass guaranteed by the supplier shall have a tolerance of $\pm 3\%$. The mass is not requested in table 3 but it shall be informed in data sheet.

7.5 DESIGNATION

7.5.1 Circular GFRP poles

The circular glass fiber reinforced polyester poles are designated as follows:

- Letters "PRFV" (equivalent to Glass Fiber Reinforced Polyester pole in Portuguese and Spanish).
- Design Load in daN (E_n).
- Total length in m (H).
- Top diameter in mm
- When the pole is equipped with the special ring support for fitting, it shall be added the letter "A" and the coupling distance (from the top of the pole till the centre of the hole in the ring support) in mm and between brackets.

7.5.2 Designation Example

Country code 230334, designation PRFV 120 – 10 – 132

**Technical Specification code: MAT-E&C-NC-2021-0057-EGIN**

Version no. 0 dated 31/12/2021

Subject: Global Infrastructure and Networks – GSS004 –Glass Fiber Reinforced Polyester Poles for Distribution Network**Application Areas**Perimeter: *Global*

Staff Function: -

Service Function: -

Business Line: *Infrastructure & Networks*

Circular Glass Fiber Reinforced Polyester Pole, nominal design load, 120 daN, total length 10 m, top diameter of 132 mm, without ring support.

Country code 230338, designation PRFV 120 – 10 – 132 A (85)

Circular Glass Fiber Reinforced Polyester Pole, nominal design load, 120 daN, total length 10 m, top diameter of 132 mm, with ring support at 85 mm from the top of the pole.

7.6 MARKING

7.6.1 Characteristics plate

The pole shall have a nameplate made of anodized aluminium or plastic material positioned at a height between 2 and 2,5 m above the theoretical ground line.

The nameplate shall include in a clear and indelible manner:

- Supplier's name
- Year and month of manufacturing
- Production batch number and serial number
- Designation according previous point (7.6)
- Weight in kg
- Additional information: Bar code and additional requirements according some countries requirements:
 - o For all countries: Bar Code according CNS-O&M-S&L-2021-0032-EGIN
 - o Spain: Spanish technical specification "UNE 0059"
 - o Brazil: Brazilian technical specification "ABNT NBR 16989" and Order number
 - o Colombia: Contract number

When the plate is made of plastic material, it could be covered with a resin layer. The resin layer shall be considered as an additional protection, being the plate resistant to UV radiation and all-weather conditions.

Subject: Global Infrastructure and Networks – GSS004 –Glass Fiber Reinforced Polyester Poles for Distribution Network

Application Areas
Perimeter: *Global*

Staff Function: -

Service Function: -

Business Line: *Infrastructure & Networks*

| | | | |
|--|--|-------|----------|
| <i>Supplier's brand</i> | | 35 mm | 115±3 mm |
| Fabrication: year and month | Weight (daN) | 20 mm | |
| <i>(text height 7mm)</i> | | | |
| Serial number/Fabrication batch | | 20 mm | |
| <i>(text height 7mm)</i> | | | |
| Designation | Height (m) | 20 mm | |
| <i>(text height 7mm)</i> | Design load E_n (daN) | 20 mm | |
| <i>(Additional according country)</i> |  | 20 mm | |
| <i>(text height 7mm)</i> | | | |

Image 6 Characteristics Plate

In Brazil the plate shall be allocated at 4 m and in Perú at 5 m, so the plate shall be adapted to be visible from the ground with text height of minimum 25 mm.

7.6.2 Risk of electric shock symbol

The poles of this standard shall be marked with the risk of electric shock symbol as represented below.



Image 7 Risk of electric shock symbol

Subject: Global Infrastructure and Networks – GSS004 –Glass Fiber Reinforced Polyester Poles for Distribution Network

Application Areas

Perimeter: *Global*

Staff Function: -

Service Function: -

Business Line: *Infrastructure & Networks*

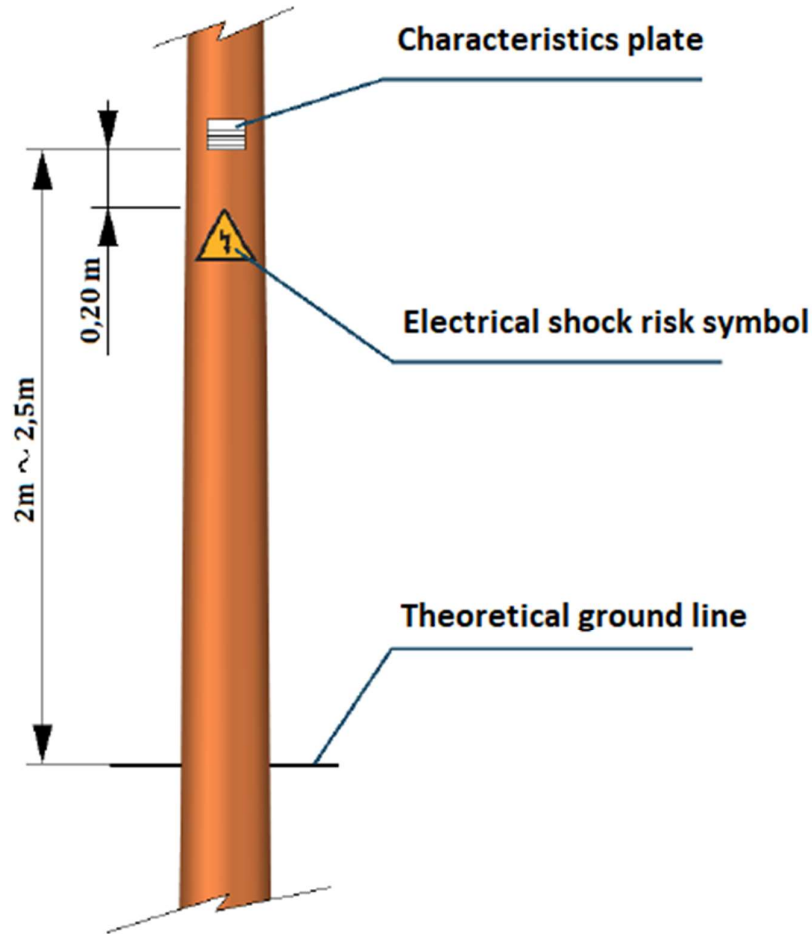

Image 8 Marking: Characteristics plate and electrical shock risk symbol

The symbol shall be according IEC 60417 – 6042, with a minimal dimension at the basis of 210 mm.

The symbol shall be fixed to the pole 0,20 m below the characteristics plate and covered with a resin layer, so that it will be visible and durable, it shall resist UV radiation.

7.6.3 Alignment

The alignment of the pole shall be marked with a vertical longitudinal line in the secondary direction, 10 mm x 400 mm. this line shall be black, and it will be positioned 1 m above the theoretical ground line. It shall be durable and resistant to UV radiation.

7.6.4 Theoretical ground line

The theoretical ground line shall be marked with a horizontal black line, 10 mm wide and with the length of half the pole, centered on the secondary direction and positioned 1 m above the theoretical ground line. It shall be

Subject: Global Infrastructure and Networks – GSS004 –Glass Fiber Reinforced Polyester Poles for Distribution Network

Application Areas

Perimeter: *Global*

Staff Function: -

Service Function: -

Business Line: *Infrastructure & Networks*

durable and resistant to UV radiation. In Brazil, this mark shall be positioned 3 m above the theoretical ground line.

7.6.5 Centre of gravity

The centre of gravity of the pole shall be marked with a black circle with a diameter of 50 mm. As all the other marks, it shall be durable and resistant to UV radiation (in Brazil, an “X” circumscribed by a circle). When the pole is composed by several sections, each section shall have its own centre of gravity marked.

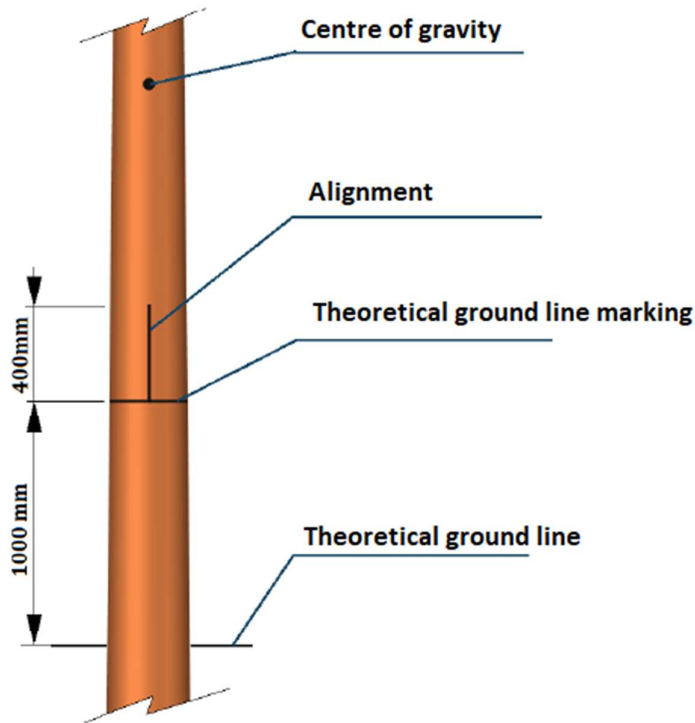

Image 9 Marking: Alignment, Theoretical ground line marking, Centre of gravity (Secondary direction)

7.6.6 Section Coupling Marking

For poles consisting in more than one section, it is needed a marking to help the installation.

The inferior section will include two horizontal lines, covering the whole perimeter of the pole, so that once installed, only the upper line will remain hidden under the superior section.

Moreover, each section shall have a vertical line to align both sections.

All these lines shall be indelible and 10 mm wide.

Subject: Global Infrastructure and Networks – GSS004 –Glass Fiber Reinforced Polyester Poles for Distribution Network

Application Areas

Perimeter: *Global*

Staff Function: -

Service Function: -

Business Line: *Infrastructure & Networks*

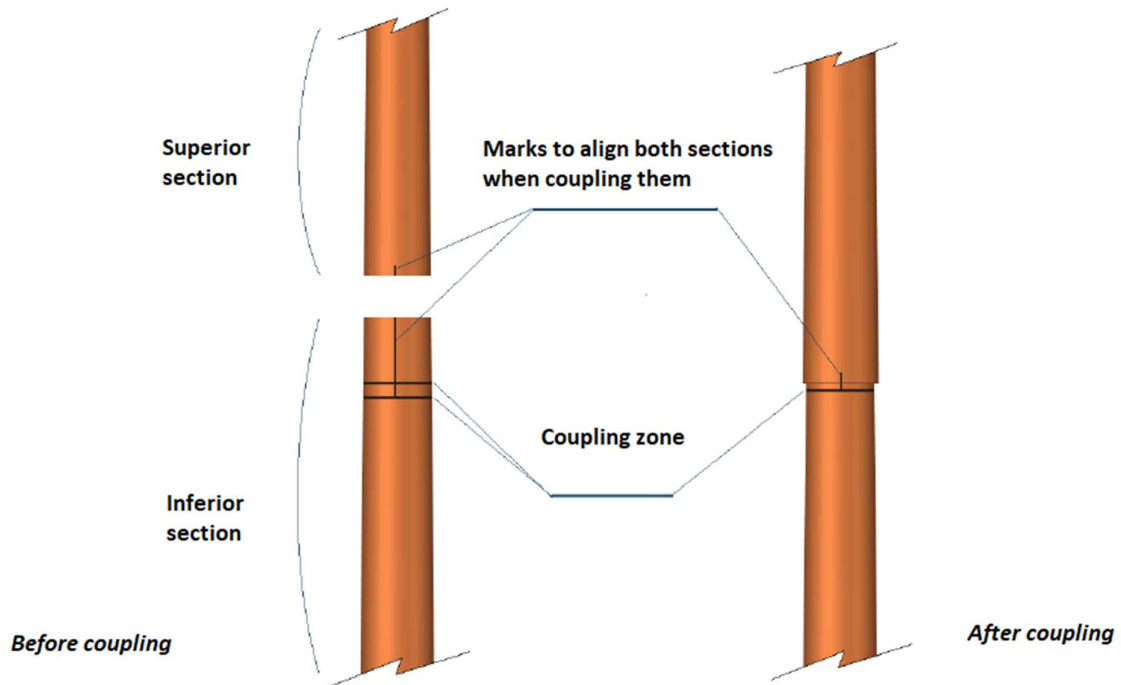

Image 10 Marks to help the coupling of different sections of a pole

In addition, each section will be marked with a removable label informing:

- Total length of the pole
- Design load in daN
- Section #1, #2 o #3

7.7 TESTING

The glass fiber reinforced poles must be tested according the following requirements.

Tests are divided into three groups:

- Type tests
- Acceptance tests:
 - o Acceptance tests to be done independently by the supplier (sometimes called routine tests)
 - o Acceptance tests to be done in presence of an Enel inspector or appointed person (sometimes called sample tests)

Type tests are performed once, during the TCA process.

Acceptance tests shall be done according the frequency described below.



Subject: Global Infrastructure and Networks – GSS004 –Glass Fiber Reinforced Polyester Poles for Distribution Network

Application Areas
Perimeter: *Global*

Staff Function: -

Service Function: -

Business Line: *Infrastructure & Networks*

7.7.1 Type Tests

These tests are intended to verify the suitability of the designs, materials and methods of manufacture (technology) as well as technical requirements. The type tests are done once, and they only shall be repeated in case of change in materials, design or manufacturing process.

Type tests could be classified in three main groups as they apply to raw materials, test specimens of the final material or the whole pole

7.7.1.1 Test applying to raw materials

| Material | # | Test | Standard | Alternative Standard |
|----------|-------|------------------------------------|----------------------------------|----------------------|
| Resin | | <i>Characteristic</i> | | |
| | 1.1.1 | Tensile modulus | 3,4 Gpa | EN 40-7 |
| | 1.1.2 | Tensile strength | 79 Mpa | EN 40-7 |
| | 1.1.3 | Ultimate elongation | 3,50% | EN 40-7 |
| | 1.1.4 | Barcol hardness | 43 | EN 40-7 |
| | 1.1.5 | Deformation temperature under load | 78 °C | EN 40-7 |
| Fiber | 1.2.1 | <i>Shape</i> | | |
| | | ∅ Round fiber | Between 15 and 20 μm | EN 40-7 |
| | 1.2.2 | <i>Composition</i> | % | |
| | | SiO ₂ | 54 | EN 40-7 |
| | | Al ₂ O ₃ | 15 | EN 40-7 |
| | | CaO - MgO | 22 | EN 40-7 |
| | | B ₂ O ₃ | 6,5 | EN 40-7 |
| | | <i>Characteristic</i> | | |
| | 1.2.3 | Tensile modulus | 72 Gpa | EN 40-7 |
| | 1.2.4 | Tensile strength | 1.500 Mpa | EN 40-7 |
| | 1.2.5 | Corrosion glass fiber curve | See requirement in this Standard | EN 40-7 |

Table 13 Test on raw materials

Technical Specification code: MAT-E&C-NC-2021-0057-EGIN

Version no. 0 dated 31/12/2021

Subject: Global Infrastructure and Networks – GSS004 –Glass Fiber Reinforced Polyester Poles for Distribution Network

Application Areas
Perimeter: *Global*

Staff Function: -

Service Function: -

Business Line: *Infrastructure & Networks*
7.7.1.2 Test applying to test specimens of the final material

| Test specimen preparation: | | | | |
|---|------------------------------------|---|-------------------------------|--|
| - Unless any other indication, test specimens shall be conditioned in a standardized atmosphere 23/50 Class 1 according EN ISO 291 | | | | |
| - Fiber percentage, water absorption, Barcol hardness, dielectric strength, tensile and bending strength before and after UV ageing and UV resistant: test specimen taken from the pole to be tested (from the lower third of the pole between the theoretical ground line and the top) | | | | |
| - Rest of the tests: test specimens prepared with the same fiber percentage as determined in the previous test, resin and additives in the same percentage as per pole manufacturing | | | | |
| # | Test | Requirement | Required Standard | Alternative standard with applicability report |
| 2.1 | Fiber percentage | Content in fiber > 50 % Weight//60% (Argentina) | EN ISO 1172 | ASTM D2734 |
| 2.2 | Water absorption | < 0,6 % | EN ISO 62 | ASTM D570 |
| 2.3 | Resistance to fire | Vertical test, V - 0 | IEC 60695-11-10 | UL 94 |
| 2.4 | Combustion speed | ≤ 25 mm/minute | ISO 3795 | ASTM D635 |
| 2.5 | Barcol Hardness | > 32 | EN 59 | ASTM D2583 |
| 2.6 | Tensile strength | > 350 MPa | EN ISO 527-1 and EN ISO 527-4 | ASTM D3039 |
| 2.7 | Bending strength | > 450 MPa | EN ISO 14125 | ASTM D790 |
| 2.8 | UV resistance (accelerated ageing) | ISO 4892-2: 2.500 h, A method (without signs of visible fibers over the surface) | EN ISO 4892-2 | ASTM G-155, ASTM G 154 2.500 h UVB 313, cycle 2 |
| 2.9 | Colour degradation after ageing | Contrast between test specimens from accelerated ageing and reference test tubes. Method "visual evaluation through contrast scale", required grade ≥ 3 | ISO 4582 | |
| 2.10 | Tensile strength after ageing | Test on test specimens from accelerated ageing, difference respect previous test tubes ≤ 5% | EN ISO 527-1 and EN ISO 527-4 | |
| 2.11 | Bending strength after ageing | Test on test specimens from accelerated ageing, difference respect previous test tubes ≤ 5% | EN ISO 14125 | |
| 2.12 | Bending temperature under load | ≥ 180 ° C | EN ISO 75-3 | ASTM D648 |
| 2.13 | Dielectric strength | ≥ 17kV/mm | EN 60243-1 | ASTM D149 |
| 2.14 | Tracking & Erosion | 2A 1,75 kV | IEC 60587 | ASTM D2303 |
| 2.15 | Density | | ISO1183-1 | ASTM D792 |
| 2.16 | Dry film hardness | Film not harmed | AAMA 615 | |



Technical Specification code: MAT-E&C-NC-2021-0057-EGIN
Version no. 0 dated 31/12/2021

Subject: Global Infrastructure and Networks – GSS004 –Glass Fiber Reinforced Polyester Poles for Distribution Network

Application Areas

Perimeter: *Global*

Staff Function: -

Service Function: -

Business Line: *Infrastructure & Networks*

| | | | | |
|------|-------------------|--|----------|--|
| 2.17 | Film adhesion | No loose | AAMA 615 | |
| 2.18 | Chemical strength | No harm in the surface with hydrochloric acid, nitric acid, cleaning agents and mortar | AAMA 615 | |

Table 14. Tests final material test tubes

7.7.1.3 Test on the complete pole

The design project of the pole shall be documented with a study by finite elements or equivalent method.

| # | Test | Requirement |
|------|--------------------------------|---|
| 3.1 | Design, dimensions and weight | Pole and documents type A & B according to this specification |
| 3.2 | Marking | According to this specification |
| 3.3 | Pole Straightness | According to this specification. Test done horizontally over the main direction and repeated after rotation around the longitudinal axis at 45°, 90° and 135° |
| 3.4 | Bending fatigue strength | Described below |
| 3.5 | Elastic bending test | Described below |
| 3.6 | Torsion test | Described below* |
| 3.7 | Lifeline test | Described below |
| 3.8 | Barcol Hardness | Described below |
| 3.9 | Impact test (IK 10) | Described below & IEC 62262 |
| 3.10 | Holes in the wall, torque | ASCE M104, described below |
| 3.11 | Holes in the wall, pull | ASCE M104, described below |
| 3.12 | Raising of poles with sections | Described below <i>Only for poles with more than one section.</i> |
| 3.13 | Horizontal flame test | Described below |
| 3.14 | Bending moment test | Exclusive for Brazil, according ABNT NBR 16989 |

(*) For Brazil Torsion test shall be done according ABNT NBR 16989

Table 15 Test on the complete pole

7.7.1.4 Bending fatigue strength test

This test verifies the pole strength to the degradation caused by bending fatigue.

The fatigue, due to the continuous effect of the wind, may change the properties of the pole. This test is a method to reproduce these repetitive effects from the wind on the pole.

Subject: Global Infrastructure and Networks – GSS004 –Glass Fiber Reinforced Polyester Poles for Distribution Network

Application Areas

Perimeter: *Global*

Staff Function: -

Service Function: -

Business Line: *Infrastructure & Networks*

Test methodology:

A hydraulic or electromechanical mechanism will simulate the repetitive effect of the wind, a swinging with an amplitude of 1,1% the clearance height of the pole (from the theoretical ground line to the top):

$$\text{Amplitude} = 0,011 \times (H-h_1)$$

This amplitude is equivalent to a wind at 48 km/h blowing perpendicularly to the line (poles, insulation chains and conductors).

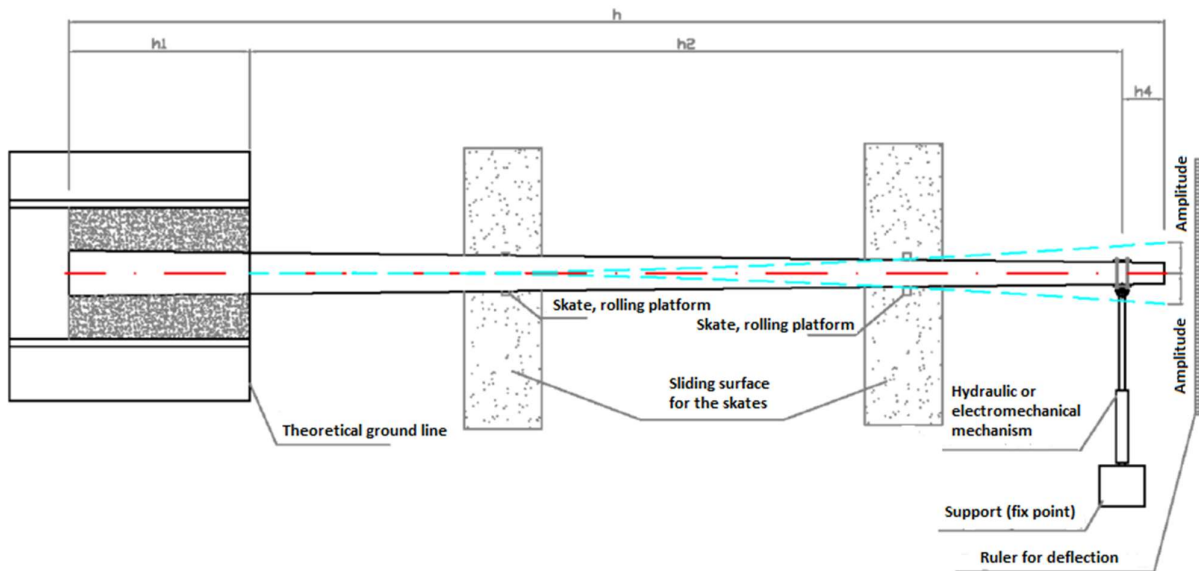

Image 11 Scheme for bending fatigue strength test

Test shall be done horizontally.

Useful length of the pole [m], $h_2 = H - h_1 - h_4$

$h_4 = d$, defined previously (0,1 m for all countries except for Spain, that applies 0,25 m)

Embedment Length [m], $h_1 = H / 10 + 0,6$ for all countries except for Spain where $h_1 = H / 10 + 0,5$

H =total length of the pole [m]

Before starting the test, the mechanism must be installed at the right distance in order to obtain the amplitude previously calculated at both sides of the longitudinal axis.

The test consists of 10^6 continuous cycles with a speed not greater than 150 cycles/min.

Note for the assembly, the support under the theoretical ground line shall be ideally made as a real foundation, as this is difficult to obtain, in any case the final support shall guarantee the contact with the complete surface of the pole. No cushions shall be considered between the support and the pole.

**Technical Specification code: MAT-E&C-NC-2021-0057-EGIN**

Version no. 0 dated 31/12/2021

Subject: Global Infrastructure and Networks – GSS004 –Glass Fiber Reinforced Polyester Poles for Distribution Network**Application Areas**Perimeter: *Global*

Staff Function: -

Service Function: -

Business Line: *Infrastructure & Networks*

The test shall be passed when no cracks or separation of layers are observed. It shall be carefully verified the zone around the support, no damage shall be found in the material.

7.7.1.5 Elastic bending test

This test will be done on the same pole previously tested with the bending fatigue test. This test serves to verify the tensile strength required.

Load application

The pole can be tested horizontally to verify the coupling between sections. Loads can be applied in a vertical or horizontal plane.

Vertical and horizontal loads are applied simultaneously.

Vertical load is applied on the vertical axis of the pole. For vertical loads greater than 1.000 daN, the load shall be applied progressively, combined with the horizontal load.

Horizontal load is gradually applied through the main direction of the pole, so to avoid dynamic impacts.

Test assembly

There are two options.

Assembly A

The main auxiliary device is a joist joined to the pole through two clamps in order to transmit the loads perpendicularly to the pole axis. The inferior clamp shall allow the movement through the pole, as his position depends on the length of the pole.

Subject: Global Infrastructure and Networks – GSS004 –Glass Fiber Reinforced Polyester Poles for Distribution Network

Application Areas

Perimeter: *Global*

Staff Function: -

Service Function: -

Business Line: *Infrastructure & Networks*

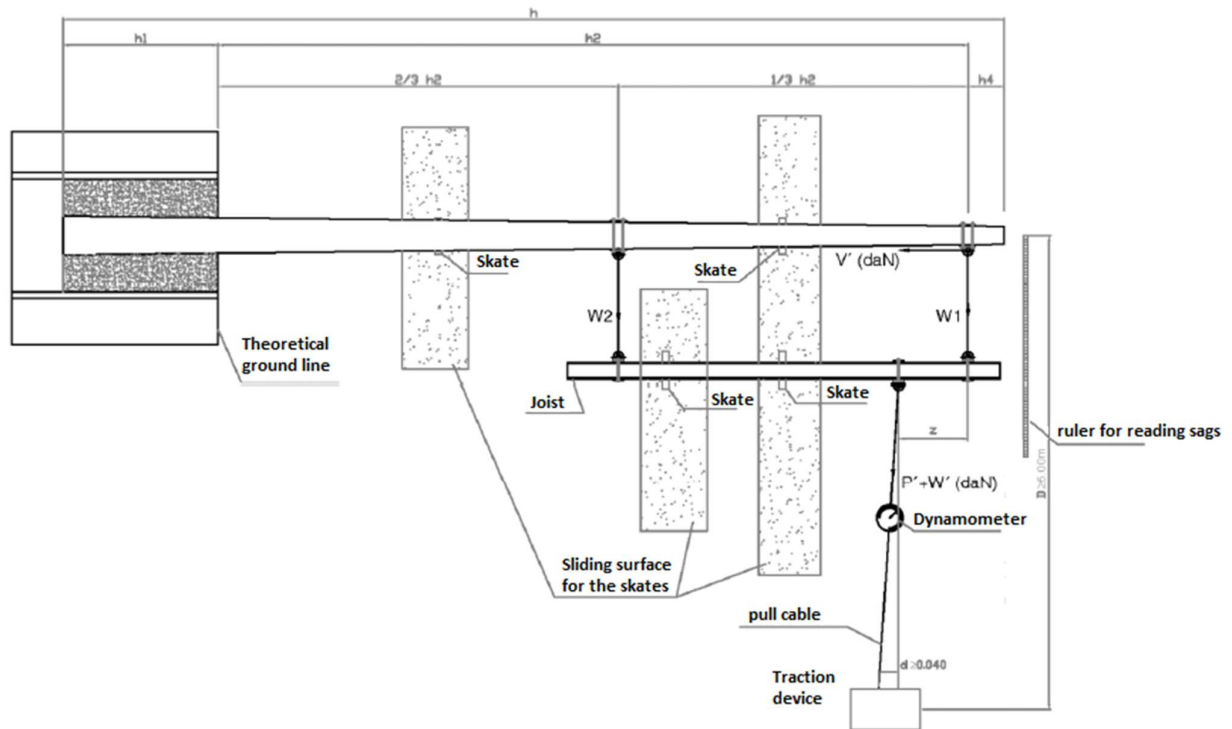

Test to be done with the pole positioned horizontally.

Image 12 Test assembly A for elastic bending test

There is a third clamp, also mobile, to apply the loads at different distances.

The ideal assembly is with a joist with length equal to a third (1/3) of the free length of the pole.

The top of the pole needs a system to measure the sags.

The joist is attached to the pole at:

- $h_4 = d$, defined previously (0,1 m for all countries except for Spain, that applies 0,25 m)
- $2/3 h_2$ from the ground line

Where:

- $h_2 = H - h_1 - h_4$ (m)
- Embedment Length [m], $h_1 = H / 10 + 0,6$ for all countries except for Spain where $h_1 = H / 10 + 0,5$
- H is the total length of the pole (m)

Assembly B

Subject: Global Infrastructure and Networks – GSS004 –Glass Fiber Reinforced Polyester Poles for Distribution Network

Application Areas

Perimeter: *Global*

Staff Function: -

Service Function: -

Business Line: *Infrastructure & Networks*

The embedment length, h_1 , is the same from assembly A. Loads shall be applied $h_4 = d$, defined previously (0,1 m for all countries except for Spain, where applies 0,25 m).

The top of the pole needs a system to measure the sags.

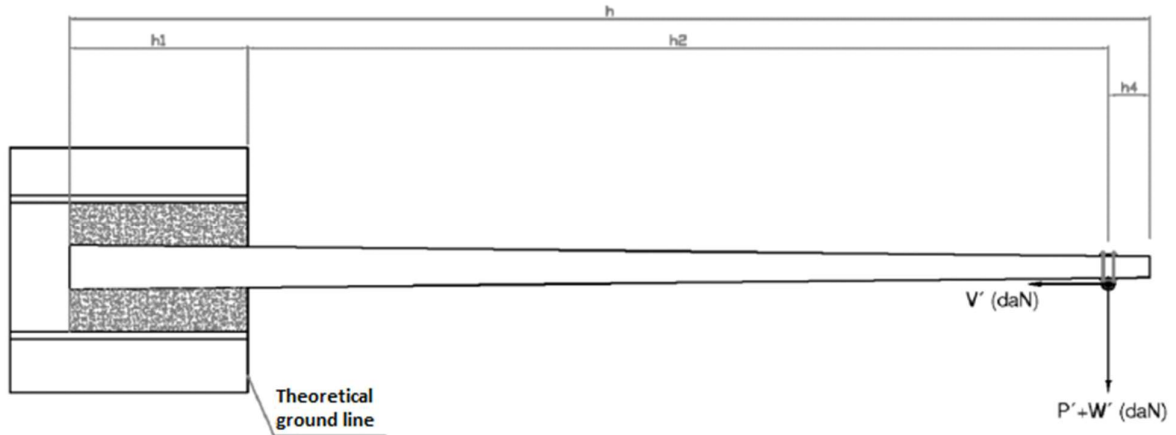

Test to be done with the pole positioned horizontally.

Image 13 Test assembly B for elastic bending test

Note, for both assemblies, A and B, the support under the theoretical ground line shall be ideally made as a real foundation, as this is difficult to obtain, in any case the final support shall guarantee the contact with the complete surface of the pole. No cushions shall be considered between the support and the pole.

Test methodology

It is required a precision of $\pm 3\%$ in applied loads and measured sags.

For assembly A

Start with a pre-load of 10 % from $(P' + W')$ required and returning to 0. Read the sag at the pre-load and also the residual sag after returning to 0 load. The residual sag is going be the point of reference for the test.

Then apply the test load $(P' + W')$ through the joist at a distance z . Apply also V' .

$$P' + W' = P' + W_1 + \frac{W_1 + W_2}{2}$$

$$z = \frac{h_2}{2} \times \frac{W_1 - W_2}{P' + W'}$$

Where:

- P' (daN) is test load according table 6 applying the security factor



Technical Specification code: MAT-E&C-NC-2021-0057-EGIN
Version no. 0 dated 31/12/2021

Subject: Global Infrastructure and Networks – GSS004 –Glass Fiber Reinforced Polyester Poles for Distribution Network

Application Areas

Perimeter: *Global*

Staff Function: -

Service Function: -

Business Line: *Infrastructure & Networks*

- W' (daN) is the load caused by the wind applying the security factor
- V' (daN) is test load according table 6 applying the security factor
- $h_1 = H/10 + 0,5$ (m)
- $h_2 = H - h_1 - h_4$ (m)
- W_1 and W_2 are loads in daN that, applied at h_4 (m) under the top, produce the same torque than those caused by wind in the ground section and at $2/3$ over, respectively, affected by the security factor.

For assembly B

Start with a pre-load of 10 % from ($P' + W'$) required and returning to 0. Read the sag at the pre-load and also the residual sag after returning to 0 load. The residual sag is going be the point of reference for the test.

Then apply the test load ($P' + W'$) and also V'

- P' (daN) is test load according tables 3 and 6 applying the security factor
- W' (daN) is the load caused by the wind (at speed according table 5) applying the security factor
- V' (daN) is test load according table 3 and 6 applying the security factor

Load steps

Sag shall be measured at the following load steps: 30%, 40%, 60%, 75%, 90%, 95% and 100%. The pole shall support the loads at 100% for 1 minute.

Then, remove the loads progressively and measure the residual sag at the end.

Acceptance criterion

With loads at 40% the sag at the top of the pole shall be as maximum as defined in table 7 and never more than 1m.

Once finished the test, the residual sag shall be as maximum as defined in table 7.

The pole shall support loads at 100% per 1 minute. After this time, no permanent deformation shall be seen (except for the elongation of the drill holes). It shall be carefully verified the zone around the support, no damage shall be found in the material.

7.7.1.6 Torsion test

The embedment length shall be the same that in previous tests, $h_1 = H/10 + 0,5$ (m), where h is the total length of the pole.

Test assembly

Subject: Global Infrastructure and Networks – GSS004 –Glass Fiber Reinforced Polyester Poles for Distribution Network

Application Areas

Perimeter: *Global*

Staff Function: -

Service Function: -

Business Line: *Infrastructure & Networks*

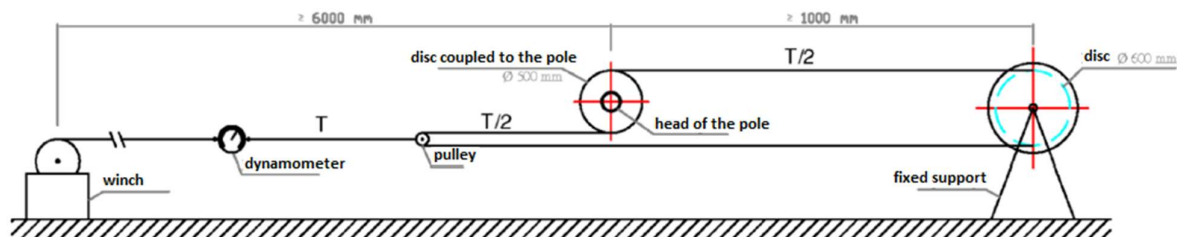

Image 14 Assembly for torsion test

They could be used greater discs, but the pulley diameter plus the diameter of the disc coupled to the pole shall be equal to the diameter of the fixed support disc.

The disc coupled to the pole shall be fixed at distance “d” from the top of the pole, defined previously (0,1 m for all countries except for Spain, that applies 0,25 m). If there was a coupling ring, the disc shall be coupled in the coupling ring.

Test methodology

It shall be applied a torsion torque equivalent to the torque caused by the test load T' in table 8 at 1.500 mm from the axis of the pole.

Vertical load and torsion torque from table 6 shall be applied simultaneously.

Vertical load is applied on the vertical axis of the pole. For vertical loads greater than 1.000 daN, the load shall be applied progressively, combined with the torsion load.

Other assemblies with equivalent test conditions are allowed.

Acceptance criterion

The pole shall support the test load at 100% for 1 minute. After this time, no permanent deformation or tear shall be appreciated, except for the elongation of the drill holes.

If the test is done with coupling rings, no tear or sliding is allowed between the pole and the ring.

NOTE: for Brazil the torsion test shall be done according to ABNT NBR 16989.

7.7.1.7 Lifeline test

The embedment length shall be the same that in previous tests, $h_1 = H/10 + 0,5$ (m), where h is the total length of the pole.

Test assembly

Subject: Global Infrastructure and Networks – GSS004 –Glass Fiber Reinforced Polyester Poles for Distribution Network

Application Areas

Perimeter: *Global*

Staff Function: -

Service Function: -

Business Line: *Infrastructure & Networks*

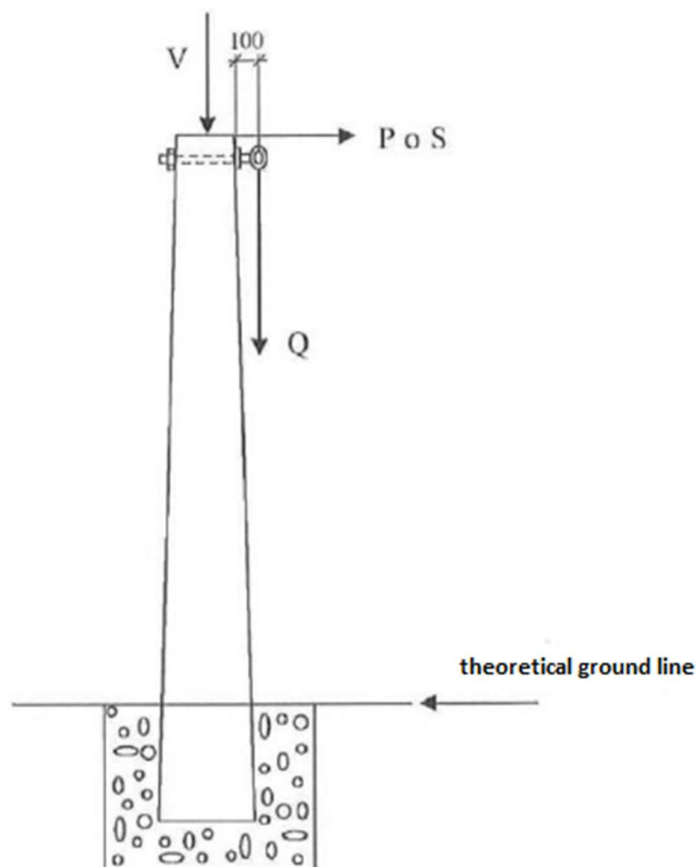

Image 15 Assembly for life line test

Where:

- V, vertical load
- P, main load
- It shall be added the wind effect (60 km/h) to P load
- Q, load equivalent to the fall of a person with weight 100 daN
- Maximum distance between the pole and the load application ring shall be 100mm.

Test methodology

Q load shall be applied simultaneously to V and P loads

Methodology A (static)

It shall be applied a load Q of 600 daN (fall of a 100 daN man) according EN 353 (1 and 2). Load shall be applied for 20 seconds as minimum.



Technical Specification code: MAT-E&C-NC-2021-0057-EGIN
Version no. 0 dated 31/12/2021

Subject: Global Infrastructure and Networks – GSS004 –Glass Fiber Reinforced Polyester Poles for Distribution Network

Application Areas

Perimeter: *Global*

Staff Function: -

Service Function: -

Business Line: *Infrastructure & Networks*

Methodology B (dynamic)

The simulation of the fall of the man for a 2m slope consists in leaving a 100 daN weight from the ring. The weight shall be attached with a device capable to absorb energy, according EN 353 (1 and 2).

Acceptance criterion

No deformation of the pole shall be found.

Note: In countries of South America it could be accepted the execution of this test according to ASCE 104 (Direct Load Shear Test)

7.7.1.8 Barcol Hardness, test on pole

The test shall be done on five points along the pole, the value shall be higher than 32 barcol.

7.7.1.9 Impact test (IK 10)

Test shall be done according IEC 62262.

Test shall include 5 impacts on the main direction and 5 impacts on the secondary direction.

Acceptance criterion

No deformation of the pole or cracks shall be found.

7.7.1.10 Holes in the wall

Document ASCE M104 gives us a guide to verify the behavior of the material when the holes are used.

Bolt Torque Test

The requirement is applying a 130 Nm torque in a bolt fixed in a drill hole of the pole.

The test is passed if the pole doesn't suffer any deformation (bolt M16 or 5/8"):

Subject: Global Infrastructure and Networks – GSS004 –Glass Fiber Reinforced Polyester Poles for Distribution Network

Application Areas

Perimeter: *Global*

Staff Function: -

Service Function: -

Business Line: *Infrastructure & Networks*

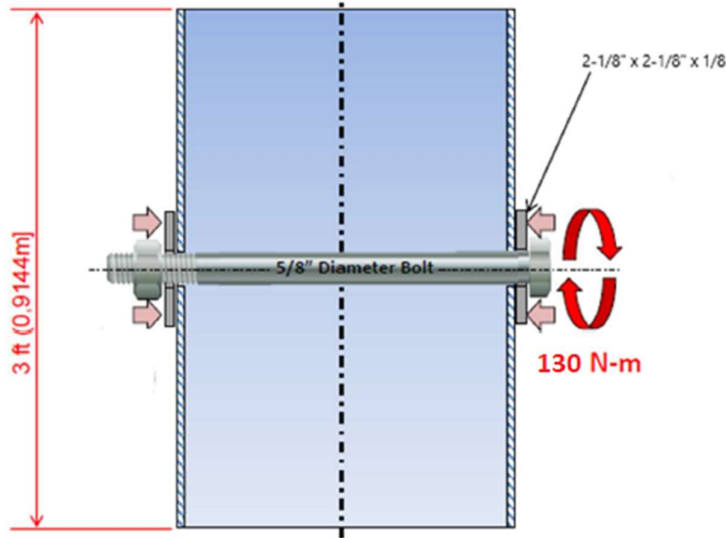

Image 16 Pole behavior, torque in bolts, ASCE 104

Bolt Pull-through Test

The requirement is applying the a load of 2.224 daN in a bolt fixed in a drill hole of the pole.

The test is passed if the pole doesn't suffer any deformation:

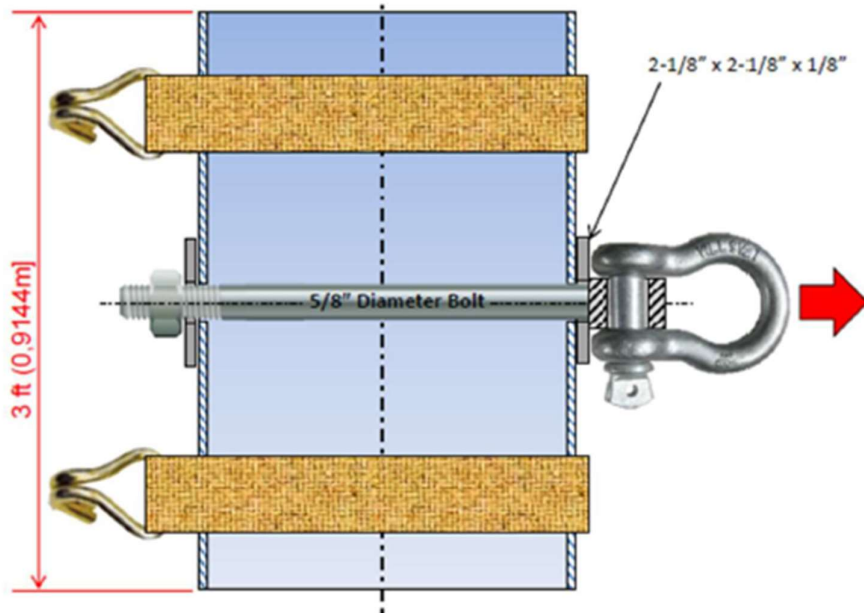

Image 17 Pole behavior, Bolt Pull-through Test, ASCE 104

Subject: Global Infrastructure and Networks – GSS004 –Glass Fiber Reinforced Polyester Poles for Distribution Network

Application Areas

Perimeter: *Global*
Staff Function: -
Service Function: -
Business Line: *Infrastructure & Networks*

7.7.1.11 Raising of poles with sections

This test only applies to poles formed by more than one section.

The object of this test is to verify that once the pole is mounted, the union remains permanently, and it can be raised and handled without any movement or fall of any section.

Test methodology

The pole shall be picked up in a point near the center of gravity with a crane and lifted for a meter, it shall remain for a time of 5 minutes, it shall be moved to a near position and then it shall be carefully placed in the ground.

The test shall be passed if the sections remain joined without any fall of a part or any movement between them.

7.7.1.12 Horizontal flame test

Assembly

The test equipment is a flame-throwing device, LPG-fueled, with outlet nozzle diameter of 50 mm.

The pole shall be allocated in a draft-free place, ignite the flamethrower device and set the pressure to 1 bar, adjust the flame to a length of 200 mm.

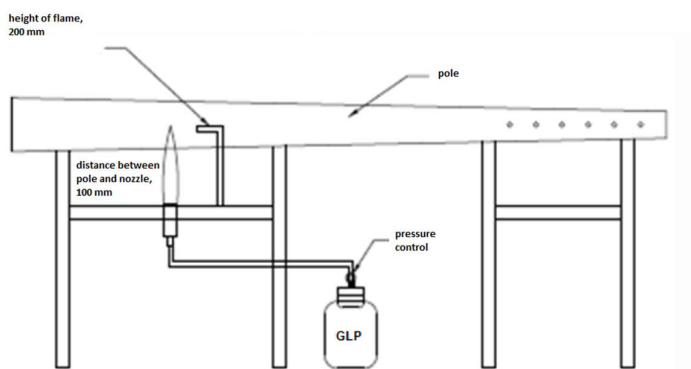

Image 18 Horizontal flame

Test methodology

Apply the flame to the pole for 60 s at three different points

(near the bottom, near the top, and along the pole). The nozzle should be at approximately 100 mm from the specimen.



Technical Specification code: MAT-E&C-NC-2021-0057-EGIN

Version no. 0 dated 31/12/2021

Subject: Global Infrastructure and Networks – GSS004 –Glass Fiber Reinforced Polyester Poles for Distribution Network

Application Areas

Perimeter: *Global*

Staff Function: -

Service Function: -

Business Line: *Infrastructure & Networks*

Acceptance criterion

After removal of the heat source, the flame cannot spread and shall be extinguished within 30 s.

7.7.2 Acceptance tests

7.7.2.1 Acceptance tests performed independently by the supplier

The aim of these tests is to eliminate poles with manufacturing defects. These tests are sometimes called routine tests.

The poles shall be produced under a permanent control system with a frequency established, including at least the test listed in 7.7.2.3.

7.7.2.2 Acceptance tests performed in presence of an Enel inspector or appointed person

These tests, sometimes called sample tests, are intended to verify characteristics of the pole, including those which depend on the quality of the manufacturing process and the materials used.

The material will be selected at random.

The manufacturer shall have available the documentation and drawings of each pole, including the documents concerning to routine tests and data that permits to verify the accomplishment of the characteristics.

Technical Specification code: MAT-E&C-NC-2021-0057-EGIN

Version no. 0 dated 31/12/2021

Subject: Global Infrastructure and Networks – GSS004 –Glass Fiber Reinforced Polyester Poles for Distribution Network

Application Areas
Perimeter: *Global*

Staff Function: -

Service Function: -

Business Line: *Infrastructure & Networks*
7.7.2.3 Test list and sample size

The test to be performed and the sampling to be applied in each case are described in the following tables. In case of small lots with various pole types, at least 1 pole per type shall always be tested.

| N° | TEST DESCRIPTION | Acceptance Test performed independently by the supplier (routine tests) | Acceptance Test repeated in the presence of an Enel inspector or appointed person (sample tests) |
|----|---|--|---|
| 1 | Verification of each batch of primary materials: resin, fiber, additives. <i>Material certificates shall confirm that their specifications are according with the requirement specified in the design and validated in type tests.</i> | 100% | Documental Check |
| 2 | Barcol hardness as per 7.8.1.2 but applied to a whole pole | 1 pole per batch and pole type | |
| 3 | Glass fiber reinforced resin Density | | |
| 4 | Design, dimensions, weight as per 7.7.1.3 | SAMPLE A | SAMPLE B |
| 5 | Marking as per 7.7.1.3 | applying the ISO 2859-1 Ed5-2007 standard according to the following criteria: Single sampling plans for normal inspection (Tab 2-A), General inspection level – LEVEL II (Tab. 1), Acceptance Quality Limit – AQL 2,5% (Tab 2-A) | applying the ISO 2859-1 Ed5-2007 standard according to the following criteria: Single sampling plans for reduced inspection (Tab 2-C), General inspection level – LEVEL II (Tab. 1), Acceptance Quality Limit – AQL 2,5% (Tab 2-C) |
| 6 | Straightness as per 7.7.1.3 | | |
| 7 | Elastic bending test as per 7.7.1.5 | 1 pole per year and pole type | Documental Check |
| 8 | Torsion test as per 7.7.1.7 | | |
| 9 | Holes in the wall, torque and pull, as per 7.7.1.11 | | |

Table 16 Acceptance tests

Technical Specification code: MAT-E&C-NC-2021-0057-EGIN

Version no. 0 dated 31/12/2021

Subject: Global Infrastructure and Networks – GSS004 –Glass Fiber Reinforced Polyester Poles for Distribution Network

Application Areas
Perimeter: *Global*

Staff Function: -

Service Function: -

Business Line: *Infrastructure & Networks*

| From | To | performed independently by the supplier | | | repeated in the presence of an Enel inspector or appointed person | | |
|------|------|--|----|----|---|----|----|
| | | Sample A | A* | R* | Sample B | A* | R* |
| 2 | 8 | 5 | 0 | 1 | 2 | 0 | 1 |
| 29 | 15 | 5 | 0 | 1 | 2 | 0 | 1 |
| 16 | 25 | 5 | 0 | 1 | 2 | 0 | 1 |
| 26 | 50 | 5 | 0 | 1 | 2 | 0 | 1 |
| 51 | 90 | 20 | 1 | 2 | 13 | 1 | 2 |
| 91 | 150 | 20 | 1 | 2 | 13 | 1 | 2 |
| 151 | 280 | 32 | 2 | 3 | 13 | 1 | 2 |
| 281 | 500 | 50 | 3 | 4 | 20 | 2 | 3 |
| 501 | 1200 | 80 | 5 | 6 | 32 | 3 | 4 |
| 1201 | 3200 | 125 | 7 | 8 | 50 | 5 | 6 |

Table 17 Sample size

* *The Acceptance (A) and Rejection (R) values are referred to the number of non-conformities detected during the tests necessary to accept or reject the whole lot.*

Note for Brazil: Some additional tests are required as per ABNT NBR 16989.

7.8 TECHNICAL CONFORMITY ASSESSMENT

Technical conformity assessment shall be done according Enel's procedure described in GSCG002. Documents type A shall include the description of the weight of raw materials and including the percentage of recycled material if any.

Local Certifications

For Colombia, RETIE certification shall be also provided according to local regulation (see 2.1).

7.9 GUARANTEE

Requirement of warranty will be indicated in the request for bids, indicating periods and standards, although any material will be warrantied 24 months as a minimum.

**Technical Specification code: MAT-E&C-NC-2021-0057-EGIN**

Version no. 0 dated 31/12/2021

Subject: Global Infrastructure and Networks – GSS004 –Glass Fiber Reinforced Polyester Poles for Distribution Network**Application Areas**Perimeter: *Global*

Staff Function: -

Service Function: -

Business Line: *Infrastructure & Networks*

7.10 CONDITIONS OF SUPPLY

Manufacturers shall provide appropriate instructions, documents showing sample and routine tests and information covering general conditions during transport, storage and installation of the poles. The instructions shall include the appropriated indications for the disassembly and recycle of the material, reporting the weight in kg of each raw material. The documents must be in English and in the local language of the destiny country. Enel will have the power to verify that the instructions given are in line with the standard practices in the sector. The instructions shall also include the information about how to treat the device at the end of its life.

As described before, for poles with more than one section, a removable label shall be included on each section and with the information of the pole and number of sections.

The requirements regarding dimensions for delivery to ENEL deposits are reported in Packaging, transport and delivery requirements.

Technical Specification code: MAT-E&C-NC-2021-0057-EGIN

Version no. 0 dated 31/12/2021

Subject: Global Infrastructure and Networks – GSS004 –Glass Fiber Reinforced Polyester Poles for Distribution Network

Application Areas
Perimeter: *Global*

Staff Function: -

Service Function: -

Business Line: *Infrastructure & Networks*
7.11 ANNEX A – COUNTRY CODE CONVERSION TO OLD SPECIFICATIONS

The following table shows the association codes for materials that have changed code from previous specification revisions with equivalent characteristics.

This table has been created using a conservative method in which the characteristics of the pole has been oversized. Other alternatives could be evaluated on a case-by-case basis.

| Global Type | Country | Country code | Designation | Replace code in previous standards | | | |
|-------------|---------|--------------|----------------------|------------------------------------|--------|--------|--------|
| | | | | | | | |
| GSS004/11 | AR | 0128-0031 | PRFV 300 - 12 - 168 | 0118-0201 | | | |
| GSS004/15 | AR | 0128-0038 | PRFV 400 - 10 - 194 | New | | | |
| GSS004/17 | AR | 0128-0037 | PRFV 400 - 12 - 194 | New | | | |
| GSS004/19 | AR | 0128-0036 | PRFV 400 - 14 - 194 | New | | | |
| GSS004/31 | AR | 0128-0035 | PRFV 600 - 12 - 238 | New | | | |
| GSS004/32 | AR | 0128-0034 | PRFV 600 - 14 - 238 | New | | | |
| GSS004/37 | AR | 0128-0033 | PRFV 800 - 10 - 280 | New | | | |
| GSS004/40 | AR | 0128-0032 | PRFV 800 - 14 - 280 | New | | | |
| GSS004/09 | BR | 230213 | PRFV 300 - 10 - 165 | New | | | |
| GSS004/12 | BR | 230212 | PRFV 300 - 12 - 170 | New | | | |
| GSS004/28 | BR | 230211 | PRFV 600 - 10 - 170 | New | | | |
| GSS004/30 | BR | 230210 | PRFV 600 - 12 - 180 | 231676 | 231673 | 327096 | 327252 |
| GSS004/32 | BR | 230209 | PRFV 600 - 14 - 238 | 601514 | 327101 | 327100 | |
| GSS004/43 | BR | 230208 | PRFV 1000 - 10 - 330 | New | | | |
| GSS004/44 | BR | 230207 | PRFV 1000 - 12 - 190 | 601512 | 327097 | | |
| GSS004/45 | BR | 230206 | PRFV 1000 - 14 - 330 | 231674 | 327102 | | |
| GSS004/46 | BR | 230126 | PRFV 1000 - 16 - 330 | New | | | |
| GSS004/47 | BR | 230125 | PRFV 2000 - 12 - 560 | 601513 | 327093 | | |
| GSS004/48 | BR | 230127 | PRFV 2000 - 14 - 560 | 231675 | 327104 | | |
| GSS004/49 | BR | 230124 | PRFV 2000 - 16 - 560 | 327106 | | | |
| GSS004/51 | BR | 230123 | PRFV 3000 - 12 - 791 | New | | | |
| GSS004/10 | CL | 230234 | PRFV 300 - 10 - 168 | New | | | |
| GSS004/13 | CL | 230232 | PRFV 300 - 14 - 168 | New | | | |
| GSS004/32 | CL | 230231 | PRFV 600 - 14 - 238 | New | | | |
| GSS004/43 | CL | 230233 | PRFV 1000 - 10 - 330 | New | | | |

Technical Specification code: MAT-E&C-NC-2021-0057-EGIN

Version no. 0 dated 31/12/2021

Subject: Global Infrastructure and Networks – GSS004 –Glass Fiber Reinforced Polyester Poles for Distribution Network

Application Areas
Perimeter: *Global*

Staff Function: -

Service Function: -

Business Line: *Infrastructure & Networks*

| Global Type | Country | Country code | Designation | Replace code in previous standards | | | |
|-------------|---------|--------------|-----------------------------|------------------------------------|--------|--|--|
| | | | | | | | |
| GSS004/48 | CL | 230230 | PRFV 2000 - 14 - 560 | New | | | |
| GSS004/49 | CL | 230229 | PRFV 2000 - 16 - 560 | New | | | |
| GSS004/52 | CL | 230235 | PRFV 3000 - 14 - 791 | New | | | |
| GSS004/05 | CO | 230228 | PRFV 294 - 10 - 168 | 231068 | | | |
| GSS004/06 | CO | 230227 | PRFV 294 - 12 - 168 | 231070 | 231071 | | |
| GSS004/07 | CO | 230226 | PRFV 294 - 14 - 168 | 231067 | | | |
| GSS004/20 | CO | 230225 | PRFV 412 - 10 - 194 | 231069 | | | |
| GSS004/21 | CO | 230224 | PRFV 412 - 12 - 194 | 231066 | | | |
| GSS004/22 | CO | 230223 | PRFV 412 - 14 - 194 | 231072 | | | |
| GSS004/23 | CO | 230222 | PRFV 412 - 16 - 194 | New | | | |
| GSS004/24 | CO | 230218 | PRFV 530 - 12 - 221 | 231086 | | | |
| GSS004/25 | CO | 230217 | PRFV 530 - 14 - 221 | 231087 | | | |
| GSS004/26 | CO | 230216 | PRFV 530 - 16 - 221 | New | | | |
| GSS004/01 | ES | 230334 | PRFV 120 - 10 - 132 | 230334 | | | |
| GSS004/01 | ES | 230338 | PRFV 120 - 10 - 132 A(85) | 230338 | | | |
| GSS004/01 | ES | 230309 | PRFV 120 - 10 - 132 A(1190) | 230309 | | | |
| GSS004/02 | ES | 230304 | PRFV 250 - 11 - 150 | 230304 | | | |
| GSS004/02 | ES | 230303 | PRFV 250 - 11 - 150 A(85) | 230303 | | | |
| GSS004/02 | ES | 230302 | PRFV 250 - 11 - 150 A(1190) | 230302 | | | |
| GSS004/03 | ES | 230301 | PRFV 250 - 12 - 150 | 230301 | | | |
| GSS004/03 | ES | 230340 | PRFV 250 - 12 - 150 A(85) | 230340 | | | |
| GSS004/03 | ES | 230299 | PRFV 250 - 12 - 150 A(1190) | 230299 | | | |
| GSS004/04 | ES | 230298 | PRFV 250 - 13 - 150 | 230298 | | | |
| GSS004/04 | ES | 230297 | PRFV 250 - 13 - 150 A(85) | 230297 | | | |
| GSS004/04 | ES | 230308 | PRFV 250 - 13 - 150 A(1190) | 230308 | | | |
| GSS004/16 | ES | 230237 | PRFV 400 - 11 - 190 | 230237 | | | |
| GSS004/16 | ES | 230256 | PRFV 400 - 11 - 190 A(85) | 230256 | | | |
| GSS004/16 | ES | 230236 | PRFV 400 - 11 - 190 A(1190) | 230236 | | | |
| GSS004/18 | ES | 230235 | PRFV 400 - 13 - 190 | 230235 | | | |
| GSS004/18 | ES | 230234 | PRFV 400 - 13 - 190 A(85) | 230234 | | | |
| GSS004/18 | ES | 230233 | PRFV 400 - 13 - 190 A(1190) | 230233 | | | |
| GSS004/34 | ES | 230079 | PRFV 630 - 11 - 250 | 230079 | | | |
| GSS004/35 | ES | 230078 | PRFV 630 - 13 - 250 | 230078 | | | |
| GSS004/36 | ES | 230077 | PRFV 630 - 15 - 250 | 230077 | | | |

Technical Specification code: MAT-E&C-NC-2021-0057-EGIN

Version no. 0 dated 31/12/2021

Subject: Global Infrastructure and Networks – GSS004 –Glass Fiber Reinforced Polyester Poles for Distribution Network

Application Areas
Perimeter: *Global*

Staff Function: -

Service Function: -

Business Line: *Infrastructure & Networks*

| Global Type | Country | Country code | Designation | Replace code in previous standards | | | |
|-------------|---------|--------------|----------------------|------------------------------------|--|--|--|
| GSS004/38 | ES | 230075 | PRFV 800 - 11 - 280 | 230075 | | | |
| GSS004/39 | ES | 230023 | PRFV 800 - 13 - 280 | 230023 | | | |
| GSS004/41 | ES | 230341 | PRFV 800 - 15 - 280 | 230341 | | | |
| GSS004/08 | PE | 230111 | PRFV 300 - 8 - 168 | 230841 | | | |
| GSS004/10 | PE | 230121 | PRFV 300 - 10 - 168 | 230834 | | | |
| GSS004/11 | PE | 230120 | PRFV 300 - 12 - 168 | 230835 | | | |
| GSS004/13 | PE | 230117 | PRFV 300 - 14 - 168 | New | | | |
| GSS004/14 | PE | 230113 | PRFV 300 - 16 - 168 | New | | | |
| GSS004/27 | PE | 230118 | PRFV 600 - 8 - 238 | New | | | |
| GSS004/29 | PE | 230122 | PRFV 600 - 10 - 238 | New | | | |
| GSS004/31 | PE | 230119 | PRFV 600 - 12 - 238 | 230865 | | | |
| GSS004/32 | PE | 230115 | PRFV 600 - 14 - 238 | 230028 | | | |
| GSS004/33 | PE | 230112 | PRFV 600 - 16 - 238 | 230027 | | | |
| GSS004/40 | PE | 230116 | PRFV 800 - 14 - 280 | New | | | |
| GSS004/42 | PE | 230110 | PRFV 800 - 16 - 280 | New | | | |
| GSS004/48 | PE | 230114 | PRFV 2000 - 14 - 560 | New | | | |
| GSS004/49 | PE | 230109 | PRFV 2000 - 16 - 560 | New | | | |
| GSS004/50 | PE | 230108 | PRFV 2000 - 20 - 560 | New | | | |

Technical Specification code: MAT-E&C-NC-2021-0057-EGIN

Version no. 0 dated 31/12/2021

Subject: Global Infrastructure and Networks – GSS004 –Glass Fiber Reinforced Polyester Poles for Distribution Network

Application Areas
Perimeter: *Global*

Staff Function: -

Service Function: -

Business Line: *Infrastructure & Networks*
7.12 ANNEX B - TECHNICAL CHECK LISTS

| Description | Units | Value |
|-----------------------------------|--------|-----------|
| 1 General information | | |
| 1.1 Global Type | | GSS004/XX |
| 1.2 Country | | |
| 1.3 Country code | | |
| 1.4 Designation | | |
| 2 Main features | | |
| 2.1 Nominal Design load, En | [daN] | |
| 2.2 Safety factor | - | |
| 2.3 Failure load, Er | [daN] | |
| 2.5 Total length | [m] | |
| 2.6 Conicity/cone angle | [mm/m] | |
| 2.7 Conicity/cone angle tolerance | [mm/m] | |
| 2.8 Top diameter | [mm] | |
| 2.9 Base diameter (informative) | [mm] | |
| 2.10 Number of sections | # | |
| 2.11 Mass | [kg] | |
| 2.12 Colour | RAL | |
| 2.13 Top and butt cover colour | RAL | |
| 2.14 Coupling ring | | |



Technical Specification code: MAT-E&C-NC-2021-0057-EGIN
Version no. 0 dated 31/12/2021

Subject: Global Infrastructure and Networks – GSS004 –Glass Fiber Reinforced Polyester Poles for Distribution Network

Application Areas

Perimeter: *Global*
Staff Function: -
Service Function: -
Business Line: *Infrastructure & Networks*

7.13 ANNEX C - TESTS REQUIRED FOR TECHNICAL CONFORMITY ASSESSMENT PROCESS

| # | Technical specification reference | Standard | | Test Description | Test applicabilty | Test Report reference | | | | Applicability report | | |
|-------|-----------------------------------|-------------------------------|--------------------------------------|----------------------------|------------------------------------|-----------------------|------------|------|--|----------------------|------|------|
| | | | | | | Name | Laboratory | Date | Name and revision of technical specification and/or standard referenced in the test report | Name | Rev. | Date |
| 1.1.1 | GSS004 7.7.1.1 | EN 40-7 | Tests on raw material | <i>Resin</i> | Tensile modulus | | | | | | | |
| 1.1.2 | GSS004 7.7.1.1 | EN 40-7 | | | Tensile strength | | | | | | | |
| 1.1.3 | GSS004 7.7.1.1 | EN 40-7 | | | Ultimate elongation | | | | | | | |
| 1.1.4 | GSS004 7.7.1.1 | EN 40-7 | | | Barcol hardness | | | | | | | |
| 1.1.5 | GSS004 7.7.1.1 | EN 40-7 | | | Deformation temperature under load | | | | | | | |
| 1.2.1 | GSS004 7.7.1.1 | EN 40-7 | | <i>Fiber</i> | Shape | | | | | | | |
| 1.2.2 | GSS004 7.7.1.1 | EN 40-7 | | | Composition | | | | | | | |
| 1.2.3 | GSS004 7.7.1.1 | EN 40-7 | | | Tensile modulus | | | | | | | |
| 1.2.4 | GSS004 7.7.1.1 | EN 40-7 | | | Tensile strength | | | | | | | |
| 1.2.5 | GSS004 7.7.1.1 | EN 40-7 | | | Corrosion glass fiber curve | | | | | | | |
| 2.1 | GSS004 7.7.1.2 | EN ISO 1172 | Tests on specimens of final material | <i>Final material GFRP</i> | Fiber percentage | | | | | | | |
| 2.2 | GSS004 7.7.1.2 | EN ISO 62 | | <i>Final material GFRP</i> | Water absorption | | | | | | | |
| 2.3 | GSS004 7.7.1.2 | IEC 60695-11-10 | | <i>Final material GFRP</i> | Resistance to fire | | | | | | | |
| 2.4 | GSS004 7.7.1.2 | ISO 3795 | | <i>Final material GFRP</i> | Combustion speed | | | | | | | |
| 2.5 | GSS004 7.7.1.2 | EN 59 | | <i>Final material GFRP</i> | Barcol Hardness | | | | | | | |
| 2.6 | GSS004 7.7.1.2 | EN ISO 527-1 and EN ISO 527-4 | | <i>Final material GFRP</i> | Tensile strength | | | | | | | |
| 2.7 | GSS004 7.7.1.2 | EN ISO 14125 | | <i>Final material GFRP</i> | Bending strength | | | | | | | |
| 2.8 | GSS004 7.7.1.2 | EN ISO 4892-2 | | <i>Final material GFRP</i> | UV resistance (accelerated ageing) | | | | | | | |
| 2.9 | GSS004 7.7.1.2 | ISO 4582 | | <i>Final material GFRP</i> | Colour degradation after ageing | | | | | | | |
| 2.10 | GSS004 7.7.1.2 | EN ISO 527-1 and EN ISO 527-4 | | <i>Final material GFRP</i> | Tensile strength after ageing | | | | | | | |
| 2.11 | GSS004 7.7.1.2 | EN ISO 14125 | | <i>Final material GFRP</i> | Bending strength after ageing | | | | | | | |
| 2.12 | GSS004 7.7.1.2 | EN ISO 75-3 | | <i>Final material GFRP</i> | Bending temperature under load | | | | | | | |
| 2.13 | GSS004 7.7.1.2 | EN 60243-1 | | <i>Final material GFRP</i> | Dielectric strength | | | | | | | |
| 2.14 | GSS004 7.7.1.2 | IEC 60587 | | <i>Final material GFRP</i> | Tracking & Erosion | | | | | | | |
| 2.15 | GSS004 7.7.1.2 | ISO1183-1 | | <i>Final material GFRP</i> | Density | | | | | | | |
| 2.16 | GSS004 7.7.1.2 | AAMA 615 | | <i>Final material GFRP</i> | Dry film hardness | | | | | | | |
| 2.17 | GSS004 7.7.1.2 | AAMA 615 | | <i>Final material GFRP</i> | Film adhesion | | | | | | | |
| 2.18 | GSS004 7.7.1.2 | AAMA 615 | | <i>Final material GFRP</i> | Chemical strength | | | | | | | |

Subject: Global Infrastructure and Networks – GSS004 –Glass Fiber Reinforced Polyester Poles for Distribution Network

Application Areas

Perimeter: *Global*
Staff Function: -
Service Function: -
Business Line: *Infrastructure & Networks*

7.14 ANNEX D - REFERENTIAL DRAWINGS

Referential drawings for hole distribution.

7.14.1 Brazil

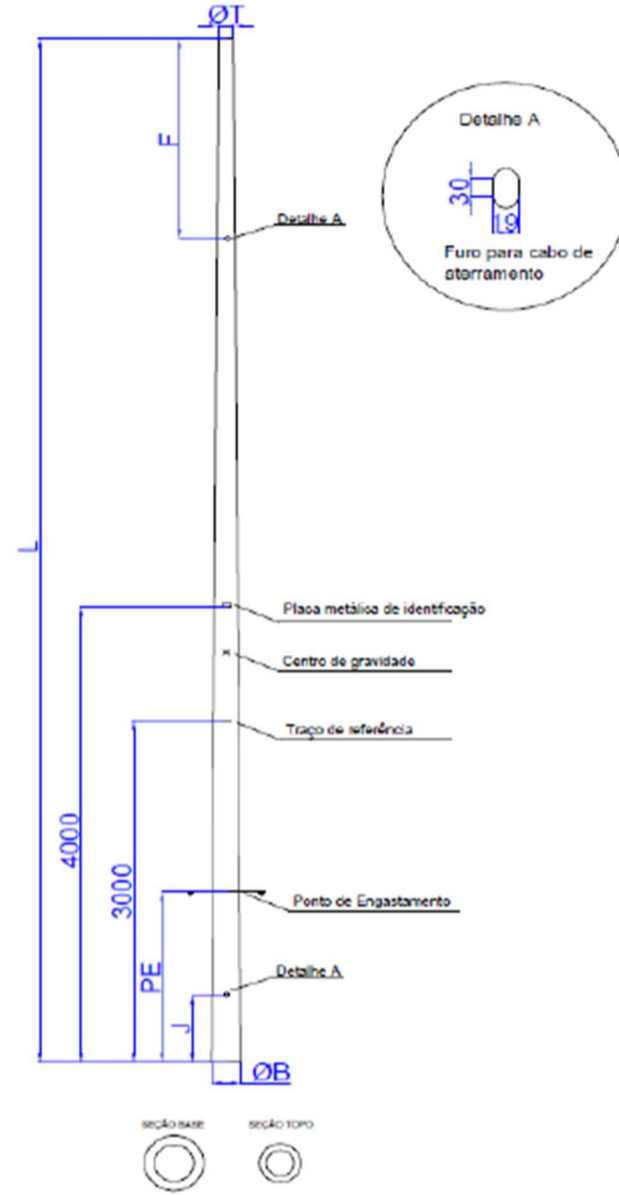

Dimensions in mm.

Subject: Global Infrastructure and Networks – GSS004 –Glass Fiber Reinforced Polyester Poles for Distribution Network

Application Areas

Perimeter: *Global*
 Staff Function: -
 Service Function: -
 Business Line: *Infrastructure & Networks*

7.14.2 Chile

7.14.2.1 Poles until 12 m

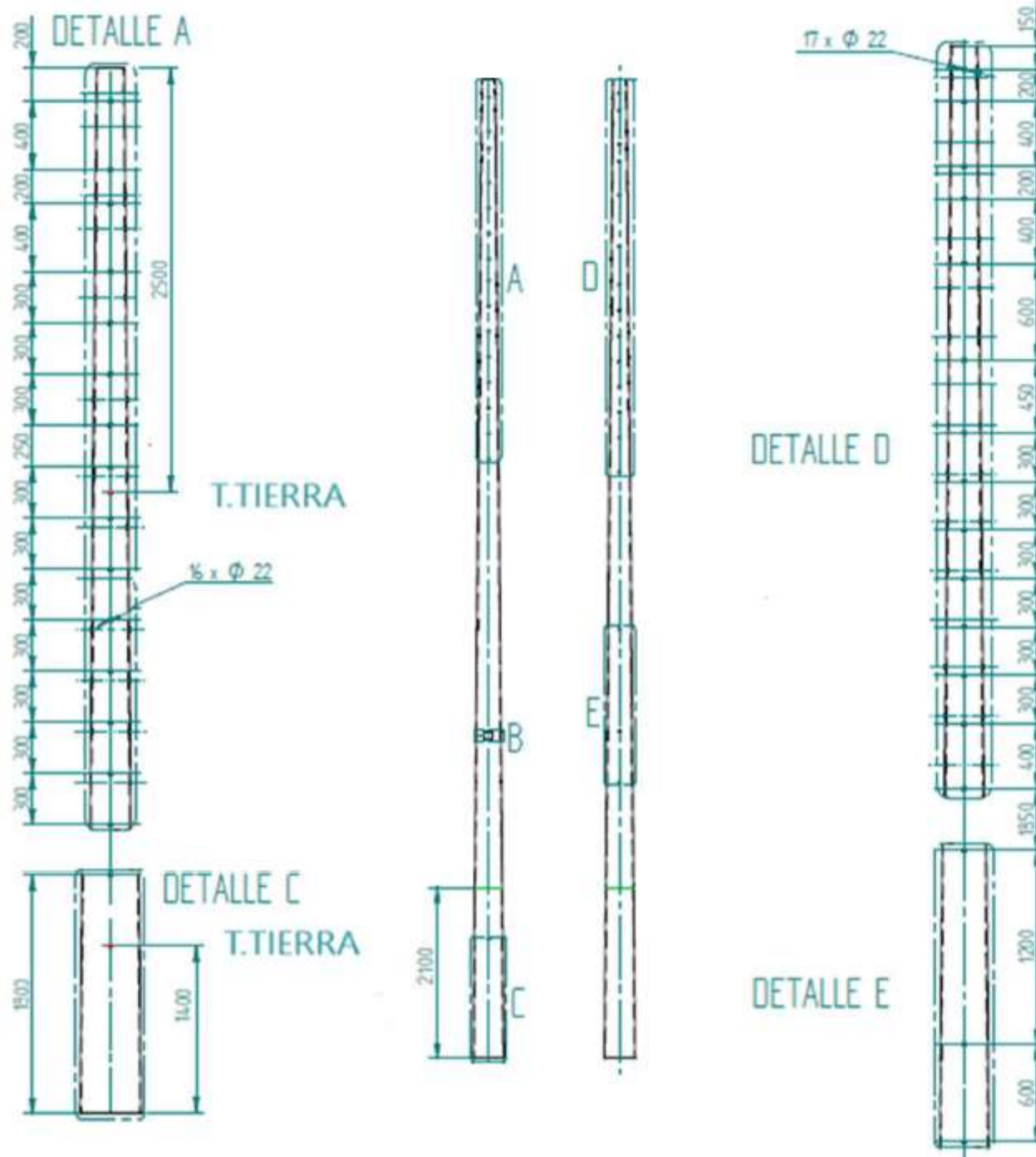

Dimensions in mm.

Subject: Global Infrastructure and Networks – GSS004 –Glass Fiber Reinforced Polyester Poles for Distribution Network**Application Areas**Perimeter: *Global*

Staff Function: -

Service Function: -

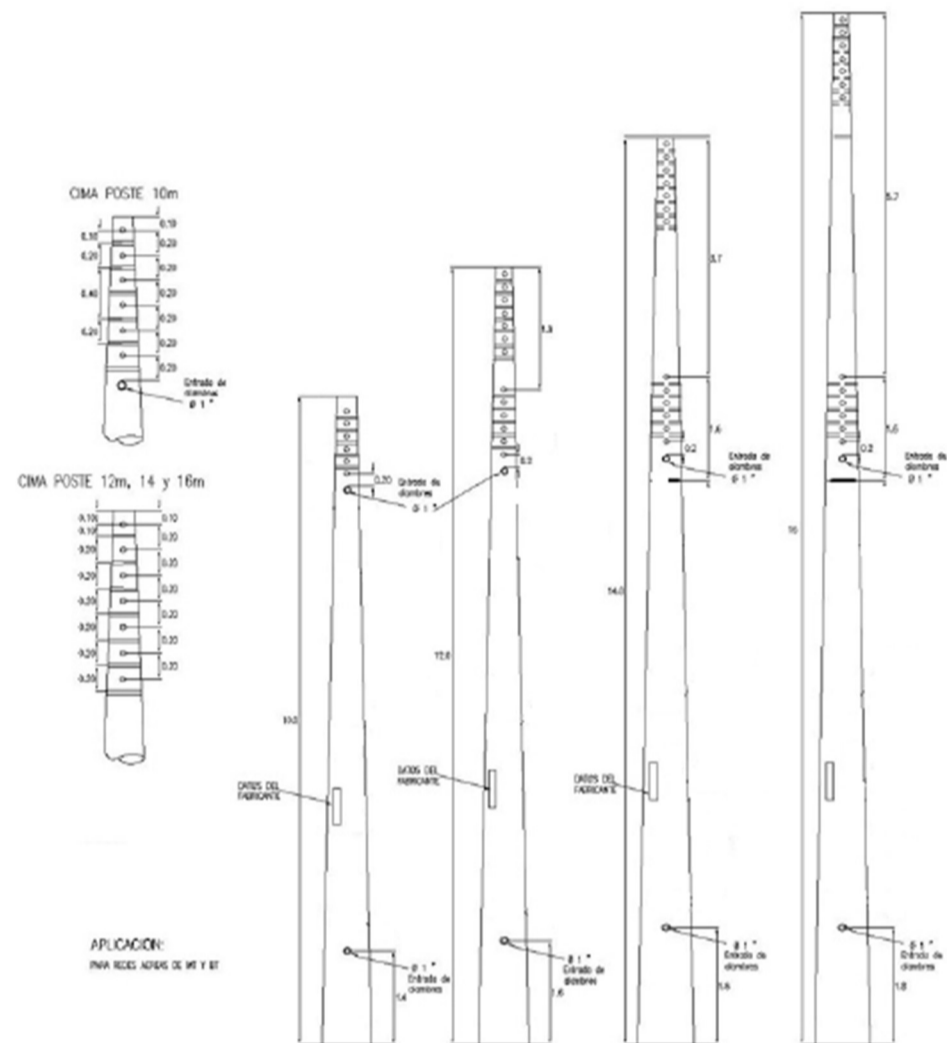
Business Line: *Infrastructure & Networks***7.14.3 Colombia**

Dimensions in m.

Subject: Global Infrastructure and Networks – GSS004 –Glass Fiber Reinforced Polyester Poles for Distribution Network

Application Areas

Perimeter: *Global*
Staff Function: -
Service Function: -
Business Line: *Infrastructure & Networks*

7.14.4 Perú

7.14.4.1 Poles until 12 m

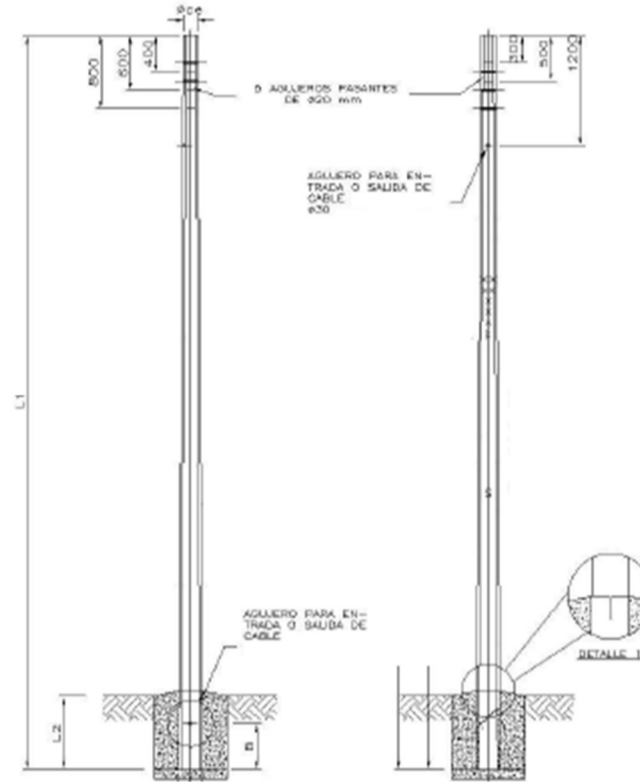

Dimensions in mm.

7.14.4.2 Poles over 12 m

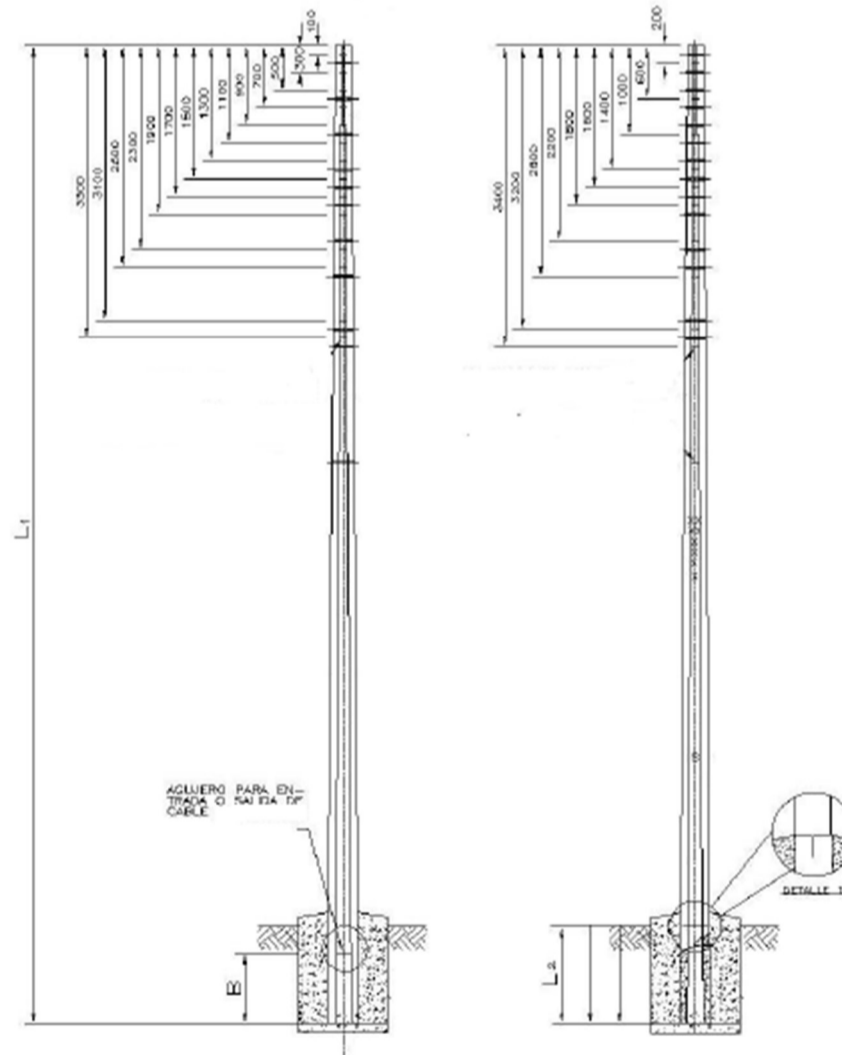

Dimensions in mm.

Subject: Global Infrastructure and Networks – GSS004 –Glass Fiber Reinforced Polyester Poles for Distribution Network

Application Areas

Perimeter: *Global*
Staff Function: -
Service Function: -
Business Line: *Infrastructure & Networks*

7.14.5 Spain

7.14.5.1 Holes for fittings, Poles until 250 daN

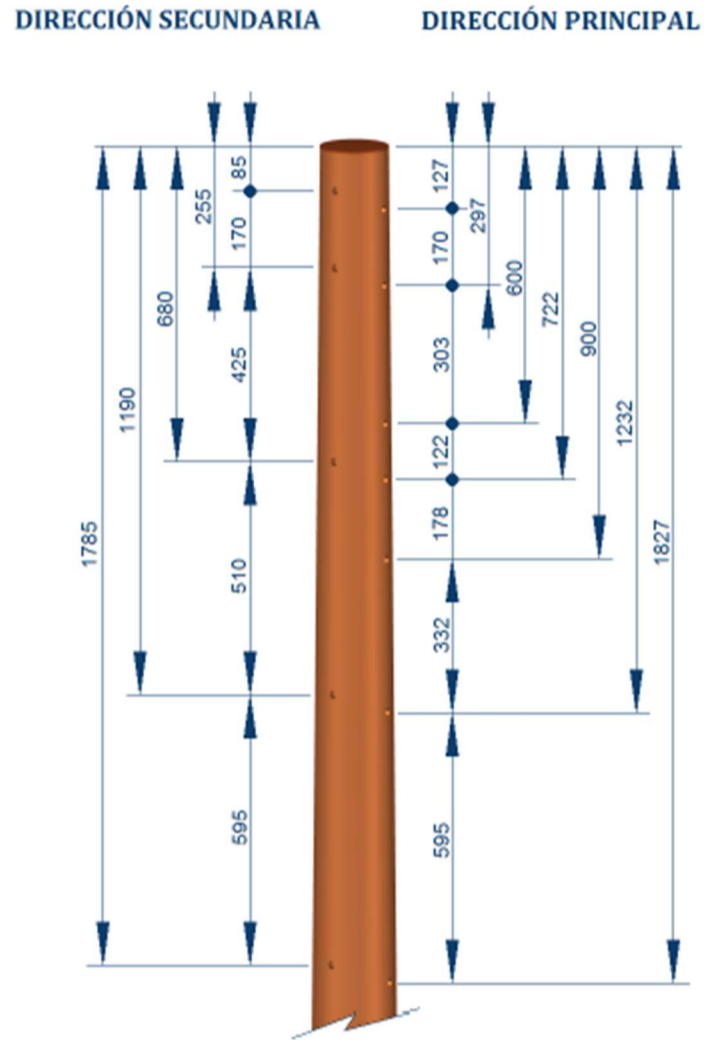

Dimensions in mm.

7.14.5.2 Holes for fittings, Poles over 250 daN

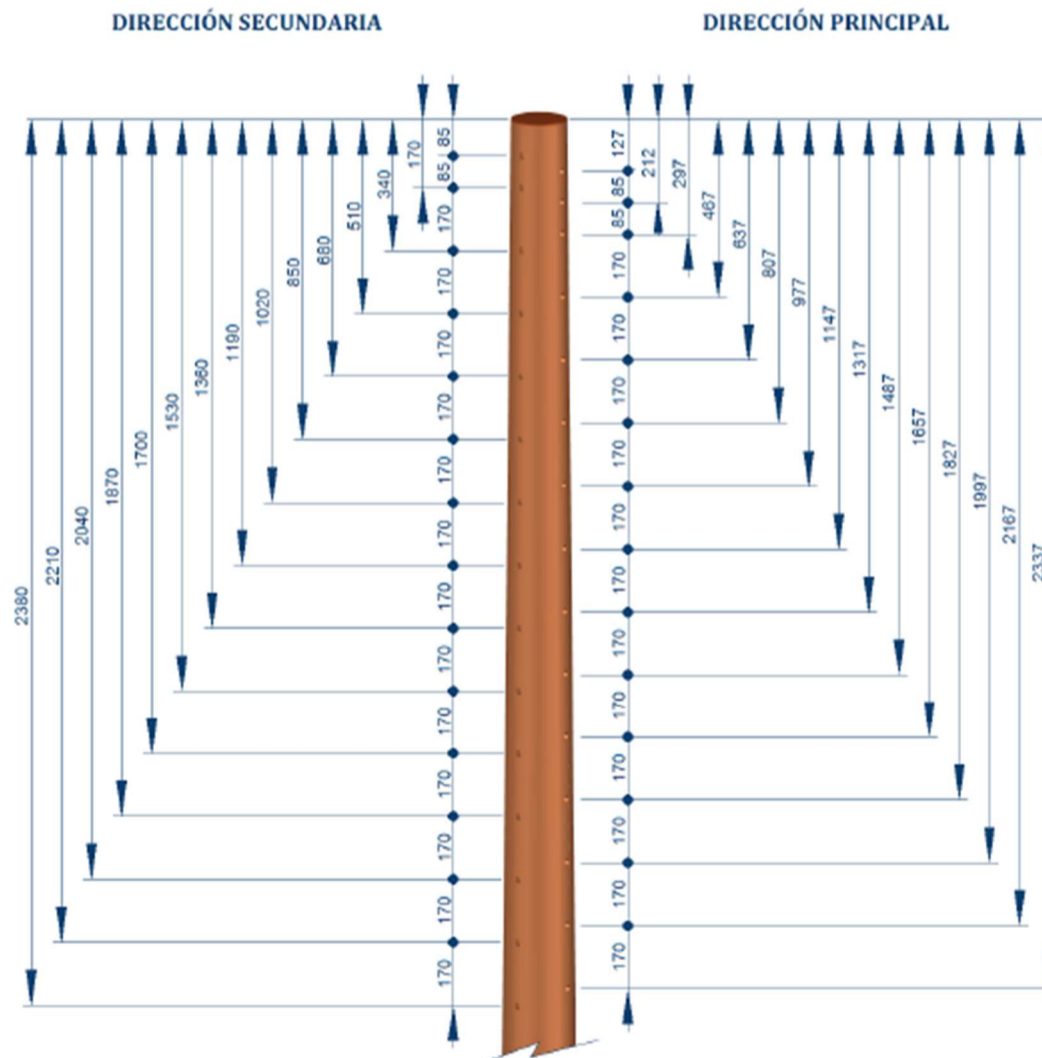

Dimensions in mm.